

Serie 4, Isı Pompalı Kurutma Makinesi, 9 kg WQA24201TR



- **AutoDry:** Tam istediğiniz derecede otomatik kurutma.
- **Hassas Kurutma Sistemi:** Kırışıklık olmadan hassas yıkama.
- **SensitiveDrying:** Özel tambur yapısı ile narin kurutma.
- **40 dakika içerisinde mükemmel kurutma.**
- **Duo-Tronic Sensör**

Ürün Tipi:Solo
Çıkarılabilir üst kapak: hayır
Kapı yönü: Sağ
Elektrik kablosu uzunluğu: 145.0 cm
Ürün Ölçüleri (Yükseklik x Genişlik x Derinlik): 842x598x613 mm
Net Ağırlık: 48.3 kg
Florlu sera gazları: Hayır
Hermetik sızdırmazlık ekipmanı:Evet
EAN numarası: 4242005467839
Güç: 600 W
Akım:10 A
Nominal gerilim:220-240 V
Frekans: 50 Hz
Kapasite: 9.0 kg
Enerji sınıfı:A++
en: Energy consumption electric dryer, full load - NEW (2010/30/EC):1.93 kWh
Standard cotton programme time at full load: 230 dakika
Energy consumption electric dryer, partial load - NEW (2010/30/EC):1.08 kWh
Standard cotton programme time at partial load: 132 dakika
Weighted annual energy consumption, electric dryer - NEW (2010/30/EC): 234.0 kWh/yıl
Weighted programme time:174 dakika
Average condensation efficiency full load (%):83 %
Average condensation efficiency partial load (%):83 %
Weighted condensation efficiency (%): 83 %

WMZ20600 :

WTZ1110 Kurutma makinesi aksesuarı
WTZ27400 Kurutma makinesi aksesuarı
WTZ27410 Kurutma makinesi aksesuarı
WTZPW20D Platform ve çekmece



**Serie 4, Isı Pompalı Kurutma
Makinesi, 9 kg
WQA24201TR**

Ölçüler mm cinsindedir

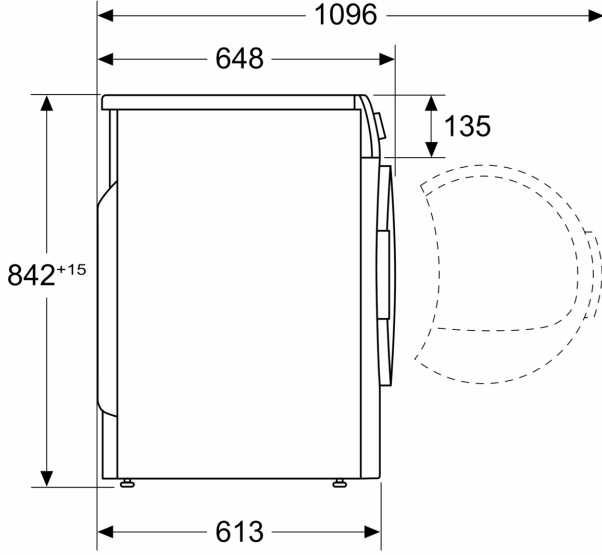

Ölçüler mm cinsindedir

