

8, Induction hob with integrated ventilation system, 80 cm, surface mount with frame PXX875D67E



HEZ9SE030 ; HEZ32WA00 ; HEZ390011 ; HEZ390012 ; HEZ39050 ; HEZ390512 ; HEZ390522 ; HEZ9ES100 ; HEZ9FE280 ; HEZ9FF010 ; HEZ9FF030 ; HEZ9FF040 ; HEZ9SE040 ; HEZ9SE060 ; HEZ9TY010 ; HEZ9VDKE1 ; HEZ9VDKR0 ; HEZ9VDKR1 ; HEZ9VDKR2 ; HEZ9VDSB1 ; HEZ9VDSB2 ; HEZ9VDSB3 ; HEZ9VDSB4 ; HEZ9VDSI0 ; HEZ9VDSI1 ; HEZ9VDSM1 ; HEZ9VDSM2 ; HEZ9VDSS1 ; HEZ9VDSS2 ; HEZ9VEDU0 ; HEZ9VRCR0 ; HEZ9VRCR1 ; HEZ9VRPD1 ;

- **DirectSelect Premium:**
- **FlexInduction:**
- **PerfectFry:** 5
- **PowerBoost** 50%

/: Cooking zone ceramic
 Built-in / Free-standing:
 :
 (x x): 223 x 750-750 x 490-490 mm
 : 816 mm
 : 223 x 816 x 527 mm
 (x x): 430 x 940 x 660 mm
 : 27.0 .
 : 33.4 .
 : Separate
 :
 :
 : Black, Stainless steel
 : Stainless steel
 : 110.0 .
 seal:
 : Booster
 2 (kW): 3.3 kW
 : 500 m³/h
 boost : 595.0 m³/h
 : 499 m³/h
 boost : 622 m³/h
 : 69 dB(A) re 1 pW
 :
 :
 : 220-240/380-415 V
 : 50-60 Hz



**8, Induction hob with integrated
ventilation system, 80 cm, surface
mount with frame
PXX875D67E**

8, Induction hob with integrated ventilation system, 80 cm, surface mount with frame PXX875D67E

measurements in mm

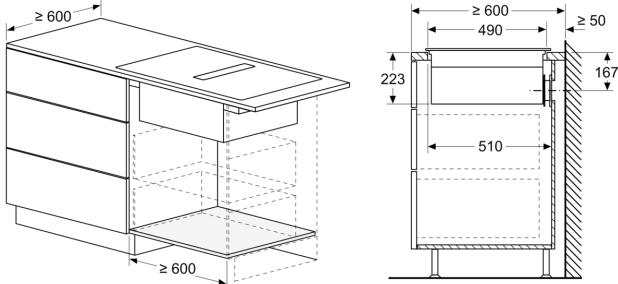

measurements in mm

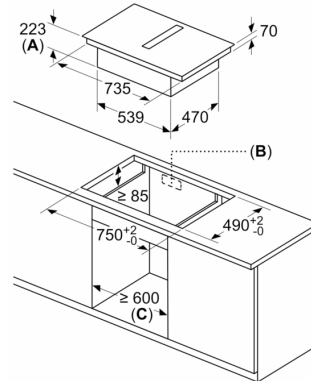

- A: Recessing depth
- B: Cut-out in back panel required for pipework. Exact size and position can be taken from specific drawing.
- C: All 80cm width class models can be installed in 60cm wide furniture by adjusting the side panels.

Measurements in mm

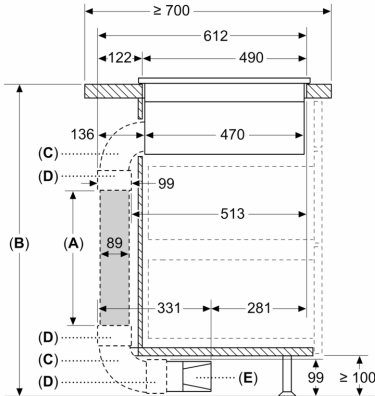

- A: Tube length
- B: Kitchen height
- C: 90° L-size bow
- D: Connector sleeve
- E: Diffusor

Ducting kit available for ≥ 700 mm depth worktops and up to 960 mm height

The installer has to select the tube length and if necessary cut it according to the kitchen height

A	B
500	≤ 960
1000	> 960

Measurements in mm

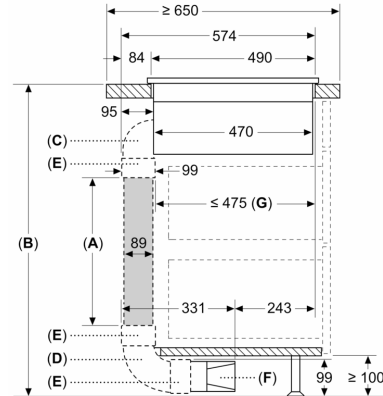

- A: Tube length
- B: Kitchen height
- C: 90° M-size bow
- D: 90° L-size bow
- E: Connector sleeve
- F: Diffusor
- G: Shortened Drawer

The installer has to select the tube length and if necessary cut it according to the kitchen height

A	B
500	≤ 940
1000	> 940

Measurements in mm

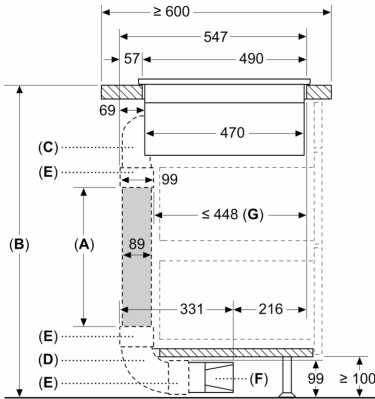

- A: Tube length
- B: Kitchen height
- C: 90° S-size bow
- D: 90° L-size bow
- E: Connector sleeve
- F: Diffusor
- G: Shortened Drawer

Ducting kit available for ≥ 600 mm depth worktops and up to 960 mm height

The installer has to select the tube length and if necessary cut it according to the kitchen height

A	B
500	≤ 990
1000	> 990

measurements in mm

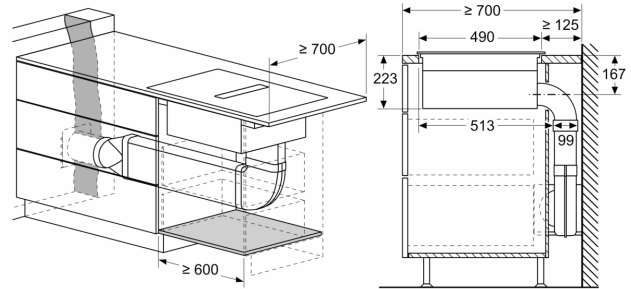

measurements in mm

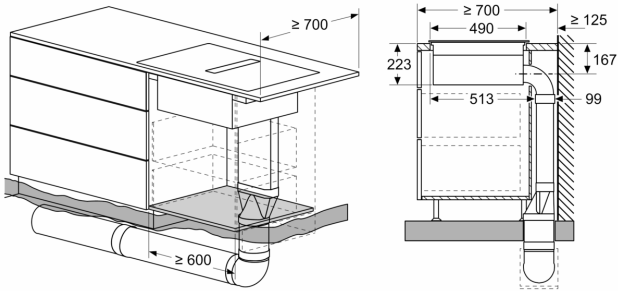

measurements in mm

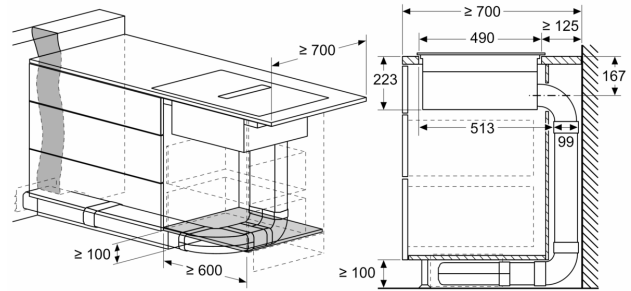

measurements in mm

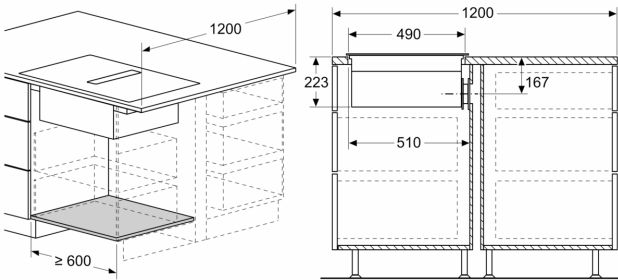

measurements in mm

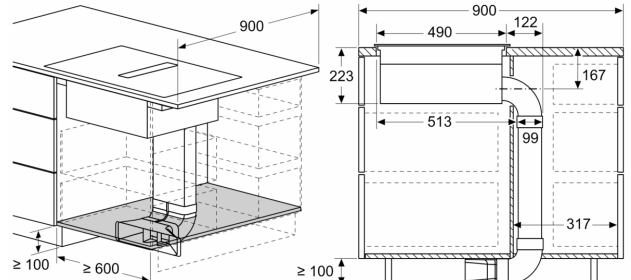

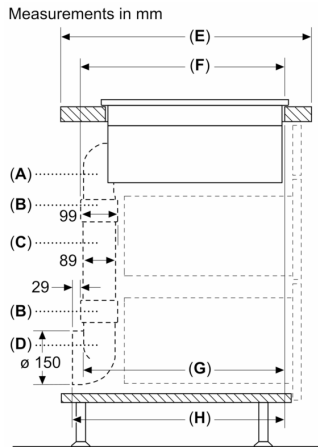

A	E	F	G	H
S-size	≥ 600	547	545	579
M-size	≥ 650	574	569	603
L-size	≥ 700	612	609	643

- A: 90° Bow
- B: Connector sleeve
- C: Straight tube
- D: 90° Adapter round-flat

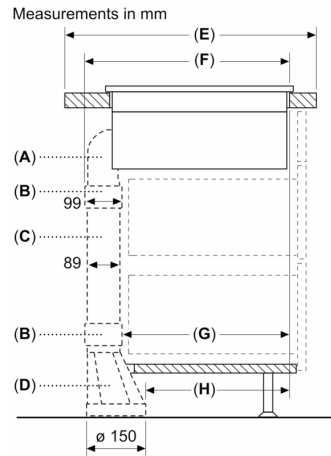

A	E	F	G	H
S-size	≥ 600	547	451	389
M-size	≥ 650	574	475	413
L-size	≥ 700	612	515	453

- A: 90° Bow
- B: Connector sleeve
- C: Straight tube
- D: Straight adapter round-flat

Measurements in mm

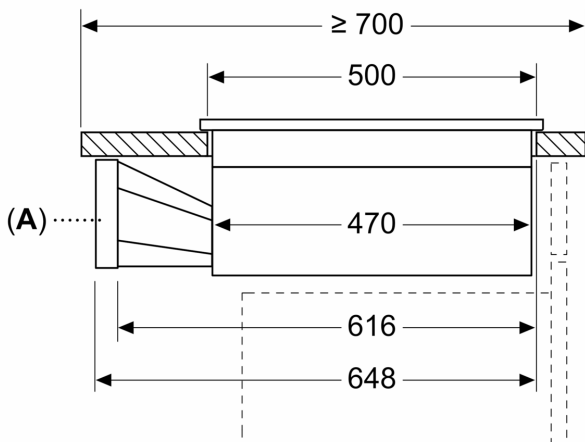

A: Adapter round-flat

measurements in mm

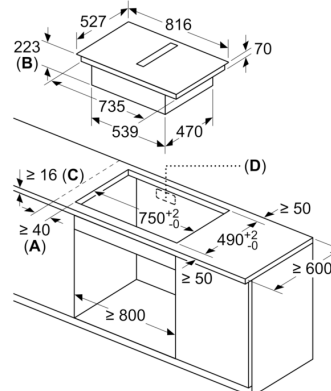

- A: Minimum distance from the hob cut-out to the wall
- B: Recessing depth
- C: The worktop into which the hob is installed must withstand loads of approx. 60kg; suitable substructures must be used if required.
- D: Cut-out in back panel required for pipework. Exact size and position can be taken from specific drawing.

measurements in mm
Front view

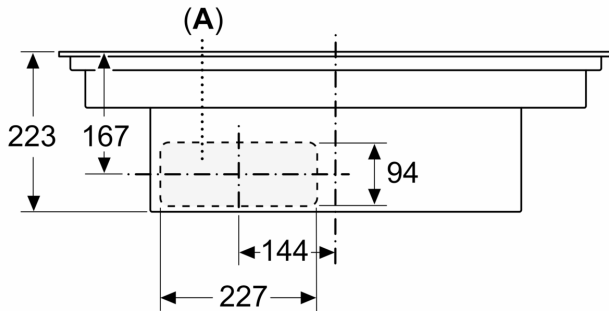

measurements in mm
Front view - unit cut-out
for unducted recirculation

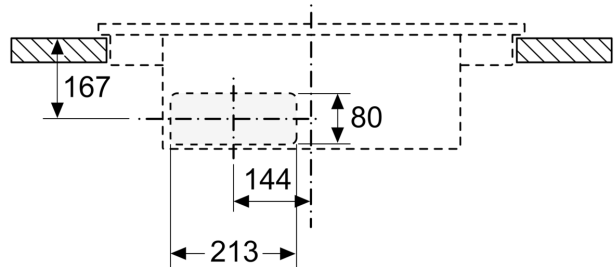

A: Connected directly at the rear

measurements in mm
Side view

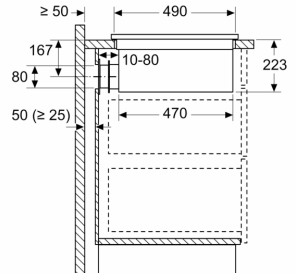

When installing directly at outer walls that are non-insulated ($\mu \geq 0.5 \text{ W/m}^2 \cdot ^\circ\text{C}$), we recommend to use partially or fully ducted recirculation configurations.

measurements in mm
Front view

