

Series 6, Heat Pump Tumble Dryer, 9 kg, Silver inox WTU87RH8ZA



A++



- WMZ20540S Platform with pull-out
- WMZ20600 Wool in basket - accessory
- WTZ2741X Stacking kit
- WTZ2742X Stacking kit with pull-out shelf

Our heatpump dryer with SelfCleaning Condenser. Great performance guaranteed with constantly low energy consumption of A++.

- **Self Cleaning Condenser:** keeps the condenser free of fluff to maintain optimal energy efficiency.
- **Auto Dry:** automatically dries to the exact degree of dryness you want.
- **Home Connect:** home appliances with smart connectivity for an easier everyday life.
- **The advanced technology of the Heat Pump compressor provides energy efficiency. In addition, with a heat pump dryer, your laundry will look good for a long time thanks to the low drying temperature.**
- **Anti Vibration Design: extremely stable and especially quiet thanks to special vibration protection.**

Built-in / Free-standing:	Free-standing
Removable top:	No
Door hinge:	Right
Length electrical supply cord:	145.0 cm
Dimensions:	842 x 598 x 613 mm
Net weight:	54.6 kg
Fluorinated greenhouse gases:	No
Type of refrigerant:	R290
Hermetically sealed equipment:	Yes
The quantity expressed in CO2 equivalent:	0.000 t
EAN code:	4242005279012
Connection rating:	800 W
Fuse protection:	10 A
Voltage:	220-240 V
Frequency:	50 Hz
Loading capacity:	9.0 kg
Energy efficiency class:	A++
Energy consumption electric dryer, full load - NEW (2010/30/EC):	1.97 kWh
Standard cotton programme time at full load:	162 min
Energy consumption electric dryer, partial load - NEW (2010/30/EC):	1.16 kWh
Standard cotton programme time at partial load:	104 min
Weighted annual energy consumption, electric dryer - NEW (2010/30/EC):	243.0 kWh/annum
Weighted programme time:	129 min
Average condensation efficiency full load (%):	91 %
Average condensation efficiency partial load (%):	91 %
Weighted condensation efficiency (%):	91 %



Series 6, Heat Pump Tumble Dryer, 9 kg, Silver inox WTU87RH8ZA

Our heatpump dryer with SelfCleaning Condenser. Great performance guaranteed with constantly low energy consumption of A++.

- selfCleaning condenser
- EcoSilence Drive
- Housing in silver inox and stainless steel

Engine power/Consumption

- Full load: 9 kg
- Dryer type: Condenser
- Energy efficiency class: A++
- Energy consumption 243.0 kWh per year, based on 160 drying cycles of the standard cotton programme at full and partial load, and the consumption of the low-power modes. Actual energy consumption per cycle will depend on how the appliance is used
- Energy consumption of the standard cotton programme at full load 1.97 kWh and energy consumption of the standard cotton programme at half load 1.16 kWh
- Power consumption in off-mode 0.1 W and in left-on mode 0.1 W
- Duration of left-on mode: 30 min
- The programme Cotton cupboard dryused at full and partial load is the standard drying programme to which the information in the label and the fiche relates, this programme is suitable for drying normal wet cotton laundry and is the most efficient programme in terms of energy consumption for cotton.
- Weighted programme time of the standard cotton programme at full and partial load: 129 min.
- Programme time of the standard cotton programme at full load 162 min and programme time of the standard cotton programme at partial load 104 min.
- Condensation efficiency class A on a scale from G (least efficient) to A (most efficient).
- Average condensation efficiency of the standard cotton programme at full load 91 % and average condensation efficiency of the standard cotton programme at partial load 91 %.
- Weighted condensation efficiency for the standard cotton programme at full and partial load: 91 %.
- Noise level: 64 dB (A) re 1 pW

Programmes

- Special programmes: Mixed Load, wool drying in basket, towels, Time program warm, Time program cold, Sportswear, downs clothes, Super 40, shirts/blouses

Options

- Touch control buttons: start/pause, Low Heat, Buzzer, Drying aim, 24 h Ready in
- Buzzer

Comfort and Safety

- SC1R
- Fully electronic control dial for sensor programmes and timed programmes
- Large touch-LED-display for Low Heat, Buzzer, Ready in, start/pause, Drying aim, Power button, Fine-tuning of drying aim,

- Child lock 3 sec., Anti-crease 60 min., Anti-crease 120 min., My favorite

- Jog dial w mech. button
- Sensitive Drying System: Big Stainless steel drum with textile care structure, soft design paddles
- Wool drying basket, Wool drying basket
- AntiVibration
- Child Lock
- Buzzer to indicate the end of cycle
- Pull-Open latch
- Container for condensed water

General Information

- Dimensions (H x W x D): 84.2 x 59.8 x 61.3 cm
- inclined ergonomic control panel, slide-under at height of 85 cm
- Heat pump technology with eco-friendly cooling agent R290

**Series 6, Heat Pump Tumble Dryer, 9
kg, Silver inox
WTU87RH8ZA**

Measurements in mm

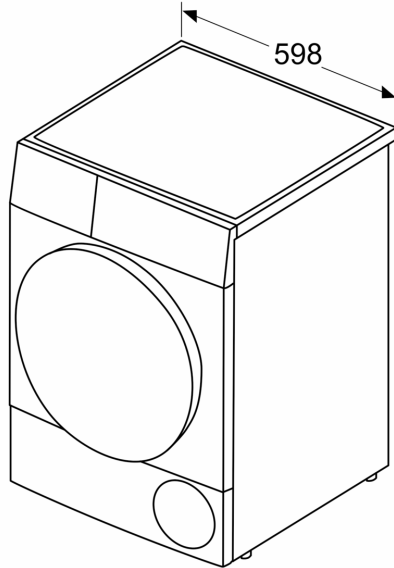

Measurements in mm

