

**iQ500, Heat Pump Tumble Dryer,
9 kg, Silver inox
WT7W466SZA**



A++

- ✓ selfCleaning condenser: Removes lint to save you time and effort.
- ✓ Save time with the fast and efficient dryers from Siemens - speedPack
- ✓ Sensor-controlled autoDry technology prevents laundry from shrinking when being dried
- ✓ Outdoor programme – Dry your waterproof and outdoor clothing safely.
- ✓ Super40: Fast and careful drying of small loads



Design: Free-standing
 Removable top: No
 Door opening: Right
 Length electrical supply cord: 145.0 cm
 Dimensions: 842 x 598 x 613 mm
 Net weight: 55.1 kg
 Fluorinated greenhouse gases: No
 Type of refrigerant: R290
 Hermetically sealed equipment: Yes
 The quantity expressed in CO2 equivalent: 0.000 t
 EAN code: 4242003825549
 Connection rating: 800 W
 Fuse protection: 10 A
 Voltage: 220-240 V
 Frequency: 50 Hz
 Capacity: 9.0 kg
 Energy efficiency: A++
 Energy consumption electric dryer, full load - NEW (2010/30/EC):
 1.97 kWh
 Standard cotton programme time at full load: 162 min
 Energy consumption electric dryer, partial load - NEW (2010/30/EC):
 1.16 kWh
 Standard cotton programme time at partial load: 104 min
 Weighted annual energy consumption, electric dryer - NEW
 (2010/30/EC): 243.0 kWh/annum
 Weighted programme time: 129 min
 Average condensation efficiency full load (%): 91 %
 Average condensation efficiency partial load (%): 91 %
 Weighted condensation efficiency (%): 91 %



WZ20530S Platform with pull-out
 WZ2741X Stacking kit

iQ500, Heat Pump Tumble Dryer, 9 kg, Silver inox WT7W466SZA

Engine power/Consumption

- Full load: 9 kg
- Dryer type: Condenser
- Energy efficiency class: A++
- Energy consumption 243.0 kWh per year, based on 160 drying cycles of the standard cotton programme at full and partial load, and the consumption of the low-power modes. Actual energy consumption per cycle will depend on how the appliance is used
- Energy consumption of the standard cotton programme at full load 1.97 kWh and energy consumption of the standard cotton programme at half load 1.16 kWh
- Power consumption in off-mode 0.1 W and in left-on mode 0.1 W
- Duration of left-on mode: 30 min
- The programme Cotton cupboard dryused at full and partial load is the standard drying programme to which the information in the label and the fiche relates, this programme is suitable for drying normal wet cotton laundry and is the most efficient programme in terms of energy consumption for cotton.
- Weighted programme time of the standard cotton programme at full and partial load: 129 min.
- Programme time of the standard cotton programme at full load 162 min and programme time of the standard cotton programme at partial load 104 min.
- Condensation efficiency class A on a scale from G (least efficient) to A (most efficient).
- Average condensation efficiency of the standard cotton programme at full load 91 % and average condensation efficiency of the standard cotton programme at partial load 91 %.
- Weighted condensation efficiency for the standard cotton programme at full and partial load: 91 %.
- Noise level: 64 dB (A) re 1 pW

Programmes

- Special programmes: Mixed Load, wool drying in basket, outdoor, towels, Pillows, Time program warm, Time program cold, Lingerie, Super 40, shirts/blouses

Options

- Anti crease cycle 120 min at the end of the programme
- Large touch-LED-display for Low Heat, Buzzer, Ready in, start/pause, Drying aim, Child lock 3 sec., Anti-crease 60 min., Anti-crease 120 min., My favorite
- Buzzer

Comfort and Safety

- SC1R
- Fully Electronic Control
- Jog dial w mech. button
- Air flow Drying System: Big Stainless steel drum structure, soft design paddles
- Wool drying basket, Wool drying basket
- AntiVibration
- Child Lock

- Buzzer to indicate the end of cycle
- Pull-Oen latch
- Container for condensed water

General Information

- Dimensions (H x W x D): 84.2 x 59.8 x 61.3 cm
- inclined ergonomic control panel, slide-under at height of 85 cm

**iQ500, Heat Pump Tumble Dryer,
9 kg, Silver inox
WT7W466SZA**

Measurements in mm

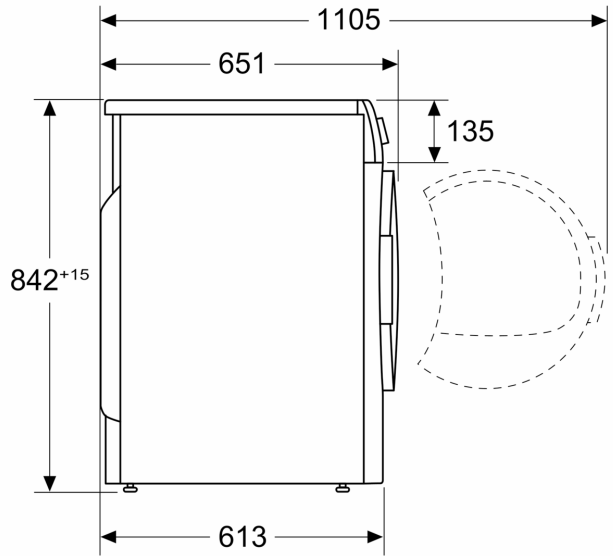

Measurements in mm

