

**iQ700, Heat Pump Tumble Dryer,
9 kg
WT47XKH1ZA**



A++



Our premium AutoClean dryer with Smart Dry and Iron Assist simplifies your laundry, as everything is done fully automatically.

- ✓ Access and control your dryer where ever you are - Home Connect App (Android and iOS).
- ✓ Sensor-controlled autoDry technology prevents laundry from shrinking when being dried
- ✓ Super40: Fast and careful drying of small loads
- ✓ intelligentDry - Lets your dryer adapt the right program to the one of your washer.
- ✓ Remote Control – Manage the laundry using your mobile device.

Design: Free-standing
 Removable top: No
 Door opening: Right
 Length electrical supply cord: 145.0 cm
 Dimensions: 842 x 598 x 613 mm
 Net weight: 56.0 kg
 Fluorinated greenhouse gases: No
 Type of refrigerant: R290
 Hermetically sealed equipment: Yes
 EAN code: 4242003887264
 Connection rating: 800 W
 Fuse protection: 10 A
 Voltage: 220-240 V
 Frequency: 50 Hz
 Capacity: 9.0 kg
 Energy efficiency: A++
 Energy consumption electric dryer, full load - NEW (2010/30/EC):
 2.10 kWh
 Standard cotton programme time at full load: 171 min
 Energy consumption electric dryer, partial load - NEW (2010/30/EC):
 1.24 kWh
 Standard cotton programme time at partial load: 109 min
 Weighted annual energy consumption, electric dryer - NEW
 (2010/30/EC): 259.0 kWh/annum
 Weighted programme time: 136 min
 Average condensation efficiency full load (%): 91 %
 Average condensation efficiency partial load (%): 91 %
 Weighted condensation efficiency (%): 91 %



WZ20600	Wool in basket - accessory
WZ27400	Stacking kit with pull-out shelf
WZ27410	Stacking kit
WZDP20D	Platform with pull-out, dryer, cubic

iQ700, Heat Pump Tumble Dryer, 9 kg WT47XKH1ZA

Engine power/Consumption

- Full load: 9 kg
- Dryer type: Condenser
- Energy efficiency class: A++
- Energy consumption 259.0 kWh per year, based on 160 drying cycles of the standard cotton programme at full and partial load, and the consumption of the low-power modes. Actual energy consumption per cycle will depend on how the appliance is used
- Energy consumption of the standard cotton programme at full load 2.1 kWh and energy consumption of the standard cotton programme at half load 1.24 kWh
- Power consumption in off-mode 0.1 W and in left-on mode 0.1 W
- Duration of left-on mode: 30 min
- The programme Cotton cupboard dryused at full and partial load is the standard drying programme to which the information in the label and the fiche relates, this programme is suitable for drying normal wet cotton laundry and is the most efficient programme in terms of energy consumption for cotton.
- Weighted programme time of the standard cotton programme at full and partial load: 136 min.
- Programme time of the standard cotton programme at full load 171 min and programme time of the standard cotton programme at partial load 109 min.
- Condensation efficiency class A on a scale from G (least efficient) to A (most efficient).
- Average condensation efficiency of the standard cotton programme at full load 91 % and average condensation efficiency of the standard cotton programme at partial load 91 %.
- Weighted condensation efficiency for the standard cotton programme at full and partial load: 91 %.
- Noise level: 62 dB (A) re 1 pW

Programmes

- standard programmes: cotton, easy care
- Iron Assist
- smartFinish
- Connected Dry
- Special programmes: Cottons, shirts/blouses, Connected Dry, Lingerie, towels, ColdRefresh_1piece, ColdRefresh_5pieces, ColdRefreshBusiness, Mixed Load, outdoor, Super 40, Synthetic, wool drying in basket, Time program warm

Options

- Anti crease cycle 120 min at the end of the programme
- Touch control buttons: Ready in, Anti-crease 60 min., Anti-crease 120 min., Child lock 3 sec., Power button, Remote Start, Low Heat, Buzzer, Start / Reload / Pause, Fine-tuning of drying aim, Drying aim, 24 h Ready in

Comfort and Safety

- SC3
- Fully Electronic Control
- Jog dial w mech. button
- TFT-Clear text display for easy use

- Large LED-Display for remaining time and 24 h end time delay, programme status indication, special functions.
- Air flow Drying System: Big Stainless steel drum structure, soft design paddles
- AntiVibration
- Wool drying basket, Wool drying basket
- Child Lock
- Buzzer to indicate the end of cycle
- Metal door catch
- Door hinge: right-hand
- Container for condensed water

General Information

- Slide-Under
- Dimensions (H x W x D): 84.2 x 59.8 x 61.3 cm
- Dimensions (H x W): 84.2 cm x 59.8 cm
- Appliance depth: 61.3 cm
- Appliance depth incl. door: 65.1 cm
- Appliance depth with open door: 110.5 cm
- Heat pump technology with eco-friendly cooling agent R290

iQ700, Heat Pump Tumble Dryer,
9 kg
WT47XKH1ZA

Measurements in mm

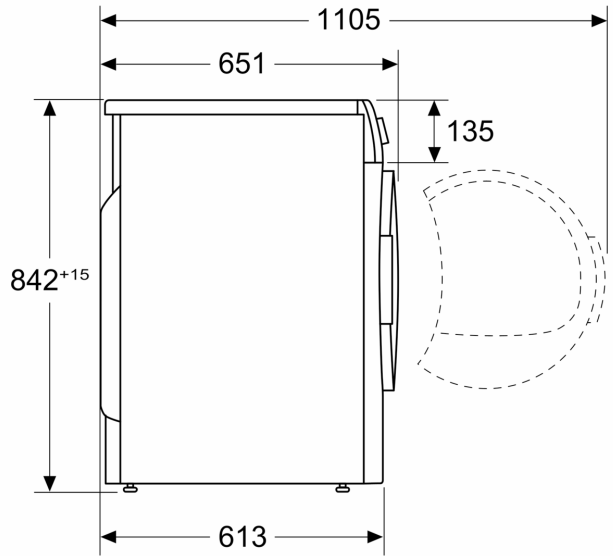

Measurements in mm

