

iQ700, Frontloader Washing Machine, 10 kg, 1600 rpm WM16XKH0ZA



Wifi-enabled washing machine with Home Connect: Enjoy the intelligent automatic dosing system and save time with the integrated speedPack.

- ✓ Remote control: Manage the laundry using your mobile device.
- ✓ 10kg Washing machines provide more capacity for your individual laundry needs.
- ✓ i-Dos: Automatically doses the precise amount of detergent and water.
- ✓ Get perfectly clean laundry in up to 65% less time with varioSpeed.
- ✓ Efficient, quiet, and durable with guarantee - iQdrive with 10 year guarantee



Maximum capacity in kg (EU 2017/1369):	10.0 kg
Design:	Free-standing
Door opening:	Left
Color / Material body:	White
Length electrical supply cord:	160.0 cm
Height of the appliance:	848 mm
Dimensions of the product:	848 x 598 x 590 mm
Wheels:	No
Net weight:	81.2 kg
Drum volume:	70 l
Connection rating:	2300 W
Fuse protection:	10 A
Voltage:	220-240 V
Frequency:	50 Hz



WX975600	Floor securing component
WZ10131	Extension for cold water inlet /Aquastop

iQ700, Frontloader Washing Machine, 10 kg, 1600 rpm WM16XKH0ZA

- Housing in White and stainless steel

Engine power/Consumption

- Capacity: 10 kg
- Energy Efficiency Class: A+++
- Energy consumption :167 kWh per year, based on 220 standard washing cycles
- Energy consumption:standard 60 °C cotton programme 0.98 kWh full load and 0.55 kWh partial load and 40 °C cotton programme 0.61 kWh partial load
- Weighted power consumption off-mode / left-on mode: 0.1 W / 0.5 W
- Water consumption 12100 litres per year, based on 220 standard washing cycles
- A spin class
- Maximum spin speed: 1600rpm
- Remaining moisture:44 %
- Programme time:60 °C cotton programme 285 min at full load 255 min at partial load and 40 °C cotton programme 180 min partial load
- Programme time:60 °C cotton programme 285 min at full load 255 min at partial load and 40 °C cotton programme 180 min partial load
- Noise level spinning:74dB (A) re 1 pW:

Programmes

- Standard programmes: cottons, easy care, delicates, wool hand wash
- Special programmes: Automatic Soft, Drum clean with reminder, Shirts/Blouses, Outdoor Wear, Spin / Drain, PowerWash 59, quick wash/mixture, Single Rinse, Super 15 min / Super 30 min

Options

- i-Dos: automatic dosing of liquid detergent and softener
- Touch control buttons: Less Ironing, On/off, Ready in, i-DOS 2.0 1, i-DOS 2.0 2, extra rinse, Remote Start, Start / Reload / Pause, Temperature Selection, varioSpeed / SpeedPerfect, Prewash, Spin speed reduction/Rinse Hold

Comfort and Safety

- Reload Function: Stop the already running washing machine to add any forgotten items of laundry to the drum.
- Large LED-Display for programme status indication, temperature selection, max. spin speed, remaining time and 24 h end time delay, i-Dos selection and consumption indication
- powerSpeed system: better washing results in less time
- XXL Drum volume: 70 l
- waveDrum: for highly effective and extremely gentle laundry care
- DrumClean with reminder function
- 32 cm porthole, chrome, white with 171° opening door
- Reload function/ pause function
- BLDC with warranty
- AntiVibration
- Precise load detection upon program start thanks to intelligent measuring technology.
- waterPerfect: resource gentle watermanagement

- Sound insulation by bottom cover
- Sound insulation by additional damping material
- Turbidity sensor
- Flow-through sensor
- Multiple water protection
- Indication of water and energy consumption prior to start of programme
- Jog dial w mech. button
- Foam detection system
- Overdosage Indication
- Safeguard monitoring system adjusts load distribution
- Child Lock
- Buzzer

General Information

- Slide-Under
- Dimensions (H x W x D): 84.8 x 59.8 x 59 cm
- Appliance depth: 59.0 cm
- Appliance depth incl. door: 63.2 cm
- Appliance depth with open door: 106.3 cm

metal Jog dial w mech. button

** Values are rounded.

**iQ700, Frontloader Washing
Machine, 10 kg, 1600 rpm
WM16XKH0ZA**

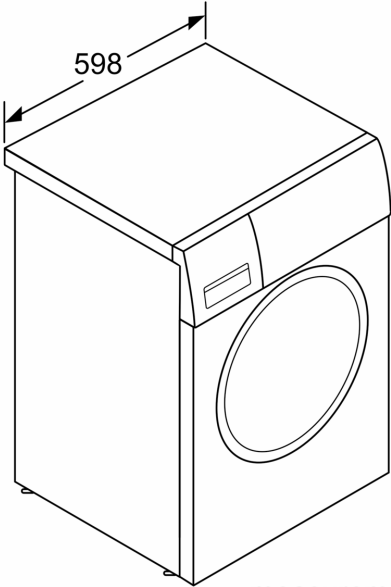

measurements in mm

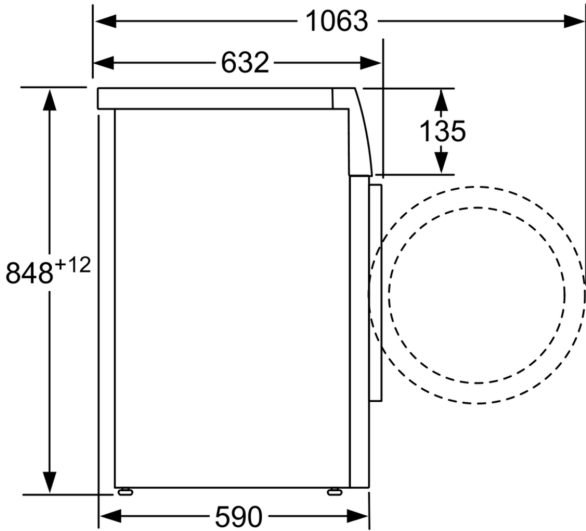

measurements in mm