

Series 4, Frontloader Washing Machine, 10 kg, , Silver inox WGA254XVZA



A+++

- The AntiStain option easily removes up to 4 of the most stubborn stains, ranging from oil, tea, cosmetics and blood helping you get the perfect washing results, easily.
- EcoSilence Drive™: extremely energy-efficient and quiet in operation with a 10-year warranty.
- Speed Perfect: perfectly clean in up to 65% less time
- .
- Allergy Plus: developed for allergy sufferers and people with sensitive skin.
- Vario Drum: gently and efficiently wash with even water distribution and without creasing garments.



Maximum capacity in kg (EU 2017/1369): 10.0 kg
 Built-in / Free-standing: Free-standing
 Door hinge: Left
 Color / Material body: Silver inox
 Length electrical supply cord: 160.0 cm
 Height of the appliance: 845 mm
 Dimensions of the product: 845 x 597 x 588 mm
 Wheels: No
 Net weight: 73.8 kg
 Drum volume: 68 l
 Connection rating: 2300 W
 Fuse protection: 10 A
 Voltage: 220-240 V
 Frequency: 50 Hz



WMZ2200 Floor securing component
 WMZ2381 Extension for cold water inlet /Aquastop

Series 4, Frontloader Washing Machine, 10 kg, , Silver inox WGA254XVZA

- WGA254XVZA
- Ferrite-BLDC
- BLDC with warranty

Engine power/Consumption

- Capacity: 10 kg
- Energy Efficiency Class: A+++
- Energy consumption :191 kWh per year, based on 220 standard washing cycles
- Energy consumption:standard 60 °C cotton programme 1.2 kWh full load and 0.6 kWh partial load and 40 °C cotton programme 0.6 kWh partial load
- Weighted power consumption off-mode / left-on mode: 0.1 W / 0.5 W
- Water consumption 12100 litres per year, based on 220 standard washing cycles
- B spin class
- Maximum spin speed: 1400rpm
- Remaining moisture:53 %
- Programme time:60 °C cotton programme 305 min at full load 290 min at partial load and 40 °C cotton programme 290 min partial load
- Programme time:60 °C cotton programme 305 min at full load 290 min at partial load and 40 °C cotton programme 290 min partial load
- Noise level spinning:75dB (A) re 1 pW:

Programmes

Options

- PreTreatment: Works against stubborn stains.
- AntiStain: Automatic removal of the most common stains.
- VarioPerfect: time- or energy optimized programs with perfect wash performance
- Touch control buttons

Comfort and Safety

- Reload function: Be flexible in adding laundry items even after start of the wash cycle.
- waveDrum
- Multiple water protection
- Large display for programme progress indication, temperature, spin speed, remaining time, 24 h end time delay and load recommendation
- Large display for temperature, spin speed, remaining time, 24 h end time delay and load recommendation
- Fully electronic control dial for all wash- and special programs
- AntiVibration Design: more stability and quietness
- 3D AquaSpa wash system with cascade for faster water penetration
- Recommended Load
- Loading introduction
- Foam detection system
- Safeguard monitoring system adjusts load distribution
- easy clean
- Overdosage Indication
- Child Lock

- Buzzer
- Metal door catch
- magnet with pull-open latch

General Information

- Dimensions (H x W x D): 84.5 x 59.7 x 58.8 cm
- Slide-Under

**Series 4, Frontloader Washing
Machine, 10 kg, , Silver inox
WGA254XVZA**

Measurements in mm

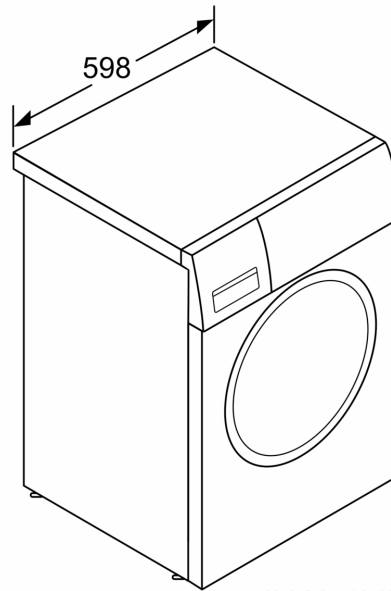
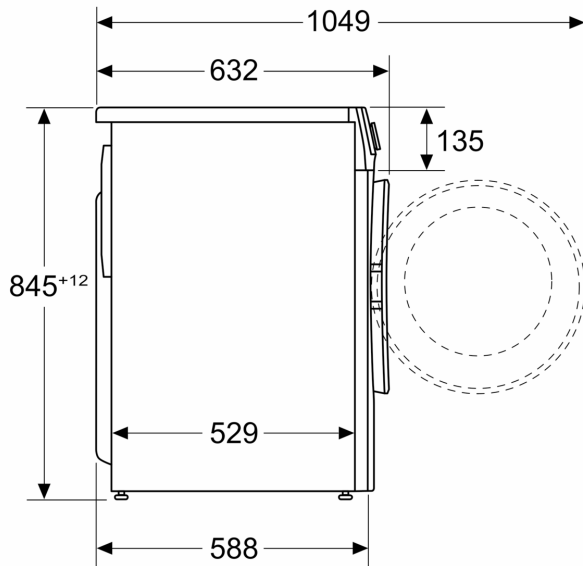

measurements in mm