

**Series 6, Frontloader Washing Machine, 9 kg, , Silver inox WGA244AXZA**



**Perfect washing results thanks to our intelligent dosing system i-DOS and AntiStain system: Reliable stain removal with the ease of automatic detergent dosing through i-DOS for the capacity of 9kg**

- With Iron Steam Assist, wrinkles on your laundry are reduced by up to 50%.
- i-DOS: automatically measures the precise amount of detergent and water needed.
- Super Quick 30 is a convenient method of freshening up light-soiled laundry in 30 minutes
- Anti Stain Plus: removes up to 16 kinds of stubborn stains without pre-treatment.
- Active Water Plus: For highly efficient use of water even with smaller loads thanks to automatic load detection.



---

Maximum capacity in kg (EU 2017/1369): .....	9.0 kg
Built-in / Free-standing: .....	Free-standing
Door hinge: .....	Left
Color / Material body: .....	Silver inox
Length electrical supply cord: .....	160.0 cm
Height of the appliance: .....	848 mm
Dimensions of the product: .....	848 x 598 x 588 mm
Wheels: .....	No
Net weight: .....	72.4 kg
Drum volume: .....	65 l
Connection rating: .....	2300 W
Fuse protection: .....	10 A
Voltage: .....	220-240 V
Frequency: .....	50 Hz

---

WMZ2200 Floor securing component  
 WMZ2381 Extension for cold water inlet /Aquastop



## Series 6, Frontloader Washing Machine, 9 kg, , Silver inox WGA244AXZA

**Perfect washing results thanks to our intelligent dosing system i-DOS and AntiStain system: Reliable stain removal with the ease of automatic detergent dosing through i-DOS for the capacity of 9kg**

- WGA244AXZA
- Ferrite-BLDC
- BLDC with warranty

### Engine power/Consumption

- Capacity: 9 kg
- Energy Efficiency Class: A+++
- Energy consumption :152 kWh per year, based on 220 standard washing cycles
- Energy consumption:standard 60 °C cotton programme 1.07 kWh full load and 0.39 kWh partial load and 40 °C cotton programme 0.39 kWh partial load
- Weighted power consumption off-mode / left-on mode: 0.12 W / 0.4 W
- Water consumption 10340 litres per year, based on 220 standard washing cycles
- B spin class
- Maximum spin speed: 1400rpm
- Remaining moisture:50 %
- Programme time:60 °C cotton programme 220 min at full load 180 min at partial load and 40 °C cotton programme 180 min partial load
- Programme time:60 °C cotton programme 220 min at full load 180 min at partial load and 40 °C cotton programme 180 min partial load
- Noise level spinning:73dB (A) re 1 pW:

### Programmes

#### Options

- PreTreatment: Works against stubborn stains.
- AntiStain: Automatic removal of the most common stains.
- VarioPerfect: time- or energy optimized programs with perfect wash performance
- Touch control buttons

#### Comfort and Safety

- Reload function: Be flexible in adding laundry items even after start of the wash cycle.
- waveDrum
- Multiple water protection
- Large display for programme progress indication, temperature, spin speed, remaining time, 24 h end time delay and load recommendation
- Large display for temperature, spin speed, remaining time, 24 h end time delay and load recommendation
- Fully electronic control dial for all wash- and special programs
- AntiVibration Design: more stability and quietness

- 3D AquaSpa wash system with cascade for faster water penetration
- Recommended Load
- Loading introduction
- Foam detection system
- Safeguard monitoring system adjusts load distribution
- Overdosage Indication
- Child Lock
- Buzzer
- Metal door catch
- magnet with pull-open latch

### General Information

- Dimensions (H x W x D): 84.8 x 59.8 x 58.8 cm
- Slide-Under
- Appliance depth incl. door: 63.2 cm
- Appliance depth with open door: 104.9 cm
- Appliance depth: 58.8 cm

**Series 6, Frontloader Washing  
Machine, 9 kg, , Silver inox  
WGA244AXZA**

Measurements in mm

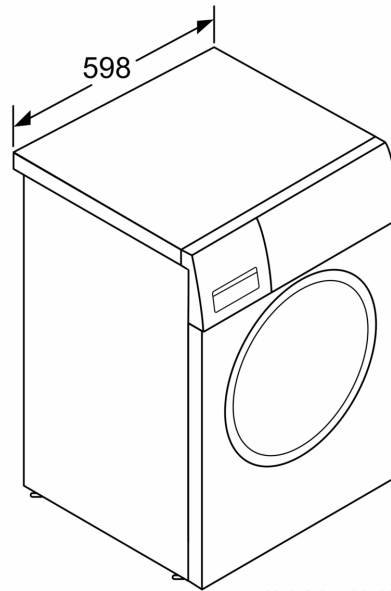
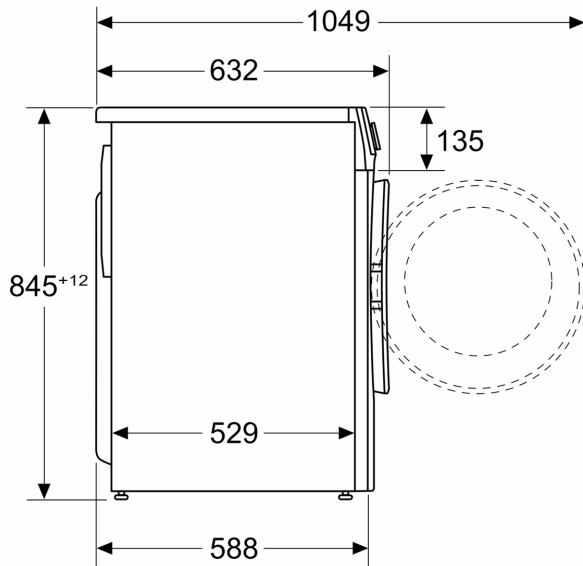

measurements in mm