

Series 2, Built-in Dishwasher, 60 cm SMV25DX00T



A+



- **EcoSilence Drive:** energy-saving and silent in operation with a long life span.
- **AquaStop:** Bosch's warranty in case of water damage – throughout the lifetime of the appliance.*
- **Height Adjustable Top Basket:** offers extra space, especially for tall dishes.

Energy Efficiency Class (Regulation (EU) 2017/1369): F
 Energy Consumption for 100 cycles Eco Programme (EU 2017/1369):
102 kWh
 Maximum number of place settings: 12
 The water consumption of the eco programme in liters per cycle (EU
 2017/1369):12.0 l
 Programme duration (EU 2017/1369): 3:30 h
 Airborne acoustical noise emissions :52 dB(A) re 1 pW
 Airborne acoustical noise emission class (EU 2017/1369): D
 Built-in / Free-standing: Built-in
 Removable top: No
 Door panel options: Not possible
 Frequency: 50; 60 Hz
 Length electrical supply cord: 175.0 cm
 Plug type: Gardy plug w/ earthing
 Length inlet hose: 165 cm
 Length outlet hose: 190 cm
 Adjustable plinth: Both horizontal and vertical
 Height of removable worktop: 0 mm
 Height of the appliance: 815 mm
 Maximum adjustability feet: 60 mm
 Dimensions of the product (HxWxD):815 x 598 x 550 mm
 Dimensions of the packed product (HxWxD): 860 x 640 x 660 mm
 Net weight:31.5 kg
 Gross weight: 33.3 kg
 Voltage: 220-240 V
 Connection rating: 2400 W
 Fuse protection: 10 A
 Hidden heating element: Yes

SGZ0BI02	decorative strips stainless steel 81,5cm
SGZ1010	inlet and outlet hose extention
SGZ8BI00	Connection rail for divided furniture
SMZ1051EU	Mains cable with EU-Plug 5m
SMZ2056	Attachment door, stainless steel
SMZ5000	Dishwashing aid set
SMZ5002	Silver polishing cassette
SMZ5003	Retractable hinge f. high corpus dimens.



Series 2, Built-in Dishwasher, 60 cm SMV25DX00T

GENERAL INFORMATION

- Capacity: 12 place settings
- Energy consumption in programme Eco50: 290 kWh per year, based on 280 standard cleaning cycles.
- Energy consumption in programme Eco 50 °C: 1.02 kWh
- Water consumption in programme Eco50: 3360 litres per year, based on 280 standard cleaning cycles.
- The information relates to the programme Eco50. This programme is suitable to clean normally soiled tableware and is the most efficient programme in terms of combined energy and water consumption.
- Programme time in programme Eco 50: 210 minutes
- Fully integrated

Performance

- 5 programmes:
- Intensive 70 °C, Eco 50 °C, Quick wash 65 °C, Quick wash 45 °C, Pre-Rinse
- 2 special options: VarioSpeed, Half Load
- 4 temperatures

Key features

- ActiveWater hydraulic water system
- DosageAssist detergent dispenser
- BLDC
- Auto 3-in-1 detergent detection for best rinsing and washing results
- Regenerative electronics

Programmes / functions

- Vario basket system
- Height adjustable top basket
- 2 foldable plate racks in bottom basket
- Cutlery basket in lower rack

Design

- Push button top controls
- Washing + drying LEDs
- Acoustic end of cycle indicator
- Red LED indicators
- LED salt refill indicator
- LED rinse aid refill indicator

Additional features

- Aquastop anti flood device with guarantee
- Aquamix - Glass protection system
- Front-adjustable rear foot
- including Steam protection plate
- Polinox drum
- Dimensions of the product (HxWxD): 81.5 x 59.8 x 55 cm

Series 2, Built-in Dishwasher, 60 cm SMV25DX00T

measurements in mm

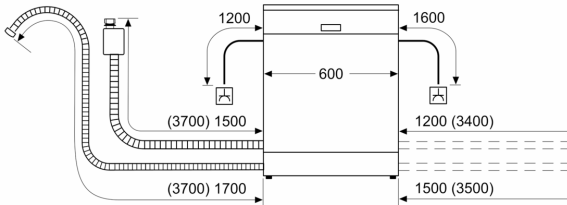

⚡ socket
() values with extension kit

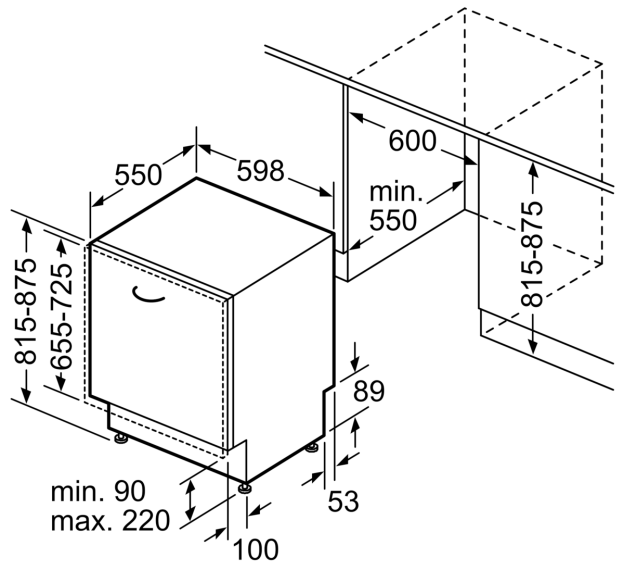

measurements in mm