

iQ300, Wall-mounted Extractor Hood, 90 cm, clear glass black printed LC95FCJ60T



B

LA10KPA6 Active carbon filter

Flat design hood: A unique look of the hood for modern kitchens.

✓ LED light: For optimal visibility and atmosphere when cooking.

Typology: Wall-mounted
 Length electrical supply cord: 118.0 cm
 Height of the appliance: 420 mm
 Minimum distance above an electric hob: 450 mm
 Minimum distance above a gas hob: 500 mm
 Net weight: 21.4 kg
 Type of control: Electronic
 Number of speed settings: 3
 Max. air extraction: 649 m³/h
 Max. recirculation: 350 m³/h
 Maximum Air flow: 649 m³/h
 Number of lights: 2
 Noise level: 68 dB(A) re 1 pW
 Diameter of air outlet: 120 / 150 mm
 Grease filter material: Washable aluminium
 EAN code: 4242003899564
 Connection rating: 252 W
 Fuse protection: 10 A
 Voltage: 220-240 V
 Frequency: 50 Hz
 Plug type: Gardy plug w/ earthing
 Installation typology: Wall-mounted



**iQ300, Wall-mounted Extractor
Hood, 90 cm, clear glass black
printed
LC95FCJ60T**

Variant:

- LC95FCJ60T
- Designed for wall mounted installation

Design:

- black with glass canopy
- touch control with Electronic display
- Removable metal grease filters, dishwasher safe

Operating and power:

- 3 speed control
- Ducted extraction rate according to DIN/EN 61591 max. 649 m³/h
- Suitable for ducted extraction and recirculation
- Recirculating kit

Comfort:

- Noise max. Normal Level: 68 dB*
- Light Intensity: 100 lux
- Colour Temperature: 4000 K

Measures:

- 89 cm wide
- Dimensions exhaust air (HxWxD): 850-1190 x 890 x 308 mm
- Dimensions recirculating (HxWxD): 965-1190 x 890 x 308 mm
- Diameter pipe Ø 150 mm (Ø 120 mm enclosed)

**iQ300, Wall-mounted Extractor Hood, 90 cm, clear glass black printed
LC95FCJ60T**

Measurements in mm

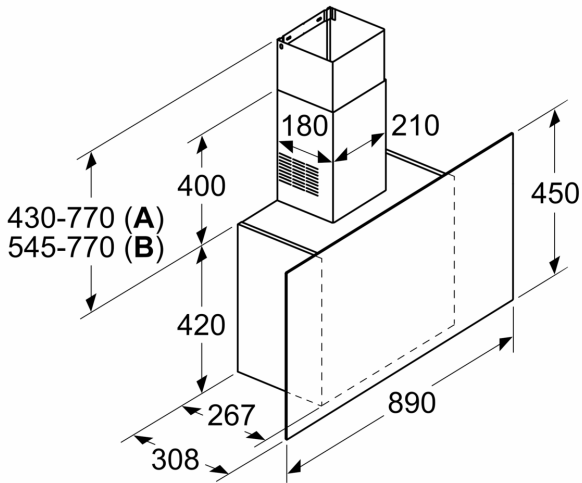

A: Exhaust air
B: Circulated air

Measurements in mm

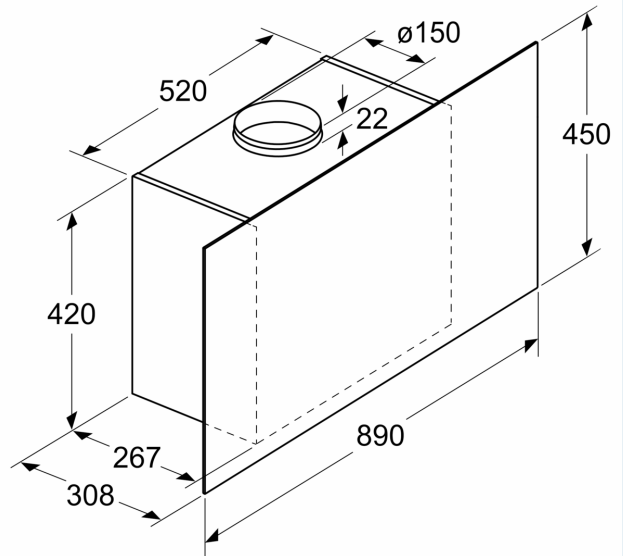

Measurements in mm

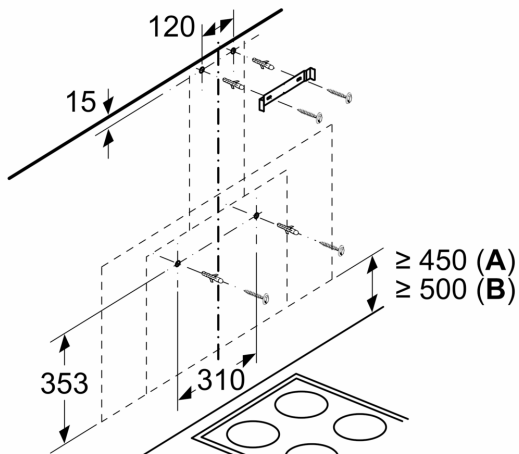

From upper edge of pan support

A: Electric
B: Gas