

**iQ100, Canopy Extractor, 53 cm,  
Anthracite  
LB53NAA30**



The powerful canopy cooker hood is concealed above the cooktop.

✓ LED light: For optimal visibility and atmosphere when cooking.

LZ10INA00	Standard odor filter (replacement)
LZ10INT00	Standard recirculation kit

**Technical Specifications**

Typology: ..... Built-in/Built-under  
 Length electrical supply cord: ..... 150.0 cm  
 Min. required niche size for installation (HxWxD): ..... 208mm x 493.0mm x 257mm mm  
 Minimum distance above an electric hob: ..... 550 mm  
 Minimum distance above a gas hob: ..... 650 mm  
 Net weight: ..... 4.5 kg  
 Type of control: ..... mechanical  
 Number of speed settings: ..... 3  
 Max. air extraction: ..... 302 m³/h  
 Max. recirculation: ..... 300 m³/h  
 Maximum Air flow: ..... 302 m³/h  
 Number of lights: ..... 2  
 Noise level: ..... 62 dB(A) re 1 pW  
 Diameter of air outlet: ..... 120 mm  
 Grease filter material: ..... Washable aluminium  
 EAN code: ..... 4242003831700  
 Connection rating: ..... 121 W  
 Fuse protection: ..... KSA A  
 Voltage: ..... 220-240 V  
 Frequency: ..... 50 Hz  
 Plug type: ..... Gardy plug w/ earthing  
 Installation typology: ..... Built-in



## iQ100, Canopy Extractor, 53 cm, Anthracite LB53NAA30

### Operating and power:

- Average Energy Consumption: 67.7 kWh/year\*
- Noise max. Normal Level: 62 dB\*

### Design:

- Suitable for ducted extraction and recirculation
- Recirculating kit
- Removable metal grease filters, dishwasher safe
- 2 x 4 W LED 3W E14
- Light Intensity: 78 lux
- Colour Temperature: 2700 K
- push buttons for extractor speeds and light
- 3 speed control
- Single motor

### Technical information:

- For recirculated extraction a recirculating kit or a CleanAir recirculation kit (accessory) is needed
- Ducted extraction rate according to DIN/EN 61591: max. 302 m<sup>3</sup>/h
- Max. extraction rate: 302 m<sup>3</sup>/h
- Dimensions (HxWxD): 208 x 534 x 300 mm
- built-in dimensions (HxWxD): 208 x 493 x 257 mm
- Power rating: 121 W
- 120 mm diameter pipe
- Yes
- Noise level according to EN 60704-3 und EN 60704-2-13 at max. normal use exhaust air: 62 dB(A) re 1 pW (48 dB(A) re 20 µPa sound pressure)

\* In accordance with the EU-Regulation No 65/2014

iQ100, Canopy Extractor, 53 cm,  
Anthracite  
LB53NAA30

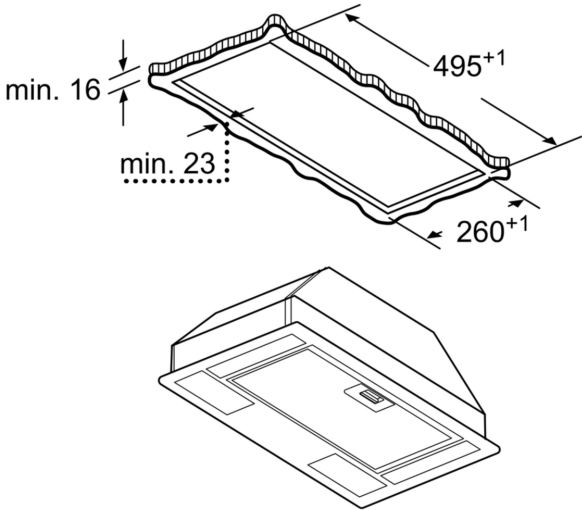

measurements in mm

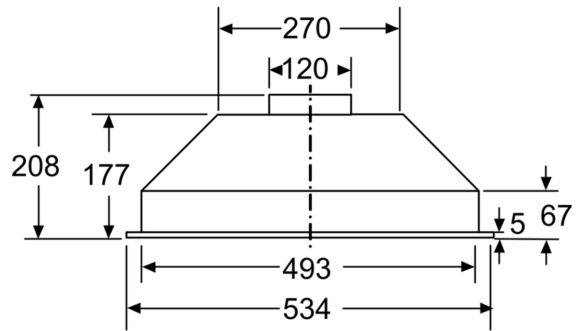

measurements in mm

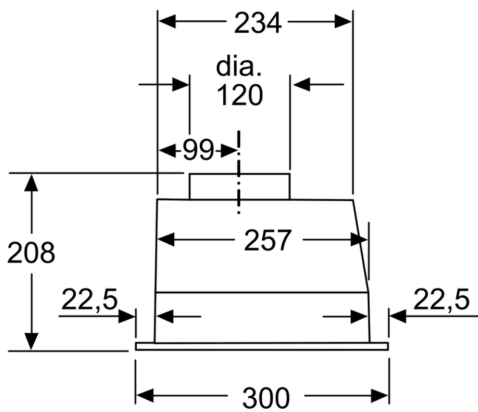

measurements in mm

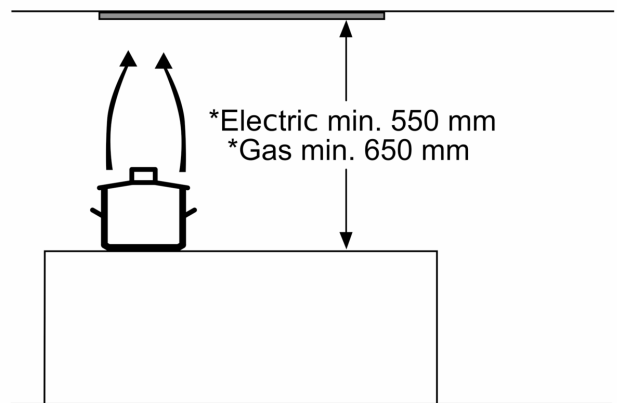

\* from upper edge of pan support

measurements in mm