

iQ700 KS36WPI30 Stainless Steel Doors

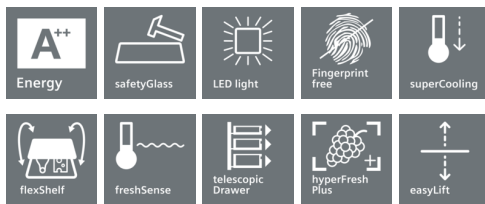

A++



iQ 700 premium refrigerator with hydroFresh Box to keep fruit and vegetables fresh up to 2 times longer, plus integrated ice&waterDispenser.

- ✓ The waterDispenser puts fresh water at your fingertips at any time.
- ✓ The hydroFresh Box with adjustable humidity keeps fruit and vegetables fresh up to 2 times longer.
- ✓ Even when fully loaded, the height of the easyLift door bin can be easily adjusted.
- ✓ The flexShelf is an extra shelf you can fold out easily when you need more room.
- ✓ An A++ cooling appliance works very efficiently.
- ✓ Cooling appliances with 90° door opening angle can be placed flush against any wall or in any niche.

Features

Technical data

Built-in / Free-standing : Free-standing
 Number of compressors : 1
 Number of independent cooling systems : 1
 Width of the product (mm) : 600
 Height (mm) : 1870
 Depth of the product : 650
 Net weight (kg) : 74.892
 Door panel options : Not possible
 Door hinge : Left
 Number of Adjustable Shelves in fridge compartment : 5
 Shelves for Bottles : Yes
 Frost free system : No
 Interior ventilator : Yes
 Reversible Door Hinge : No
 Length electrical supply cord (cm) : 230
 Noise level (dB(A) re 1 pW) : 39
 Multi-Flow Air Tower : No
 Economy setting : No
 Cold technology : 1 compressor/1 cold circuit
 Fast cooling switch : Yes
 Temperature Controlled Drawer : No
 Humidity Control Drawer : Yes
 Number of Door Bins - Refrigerator : 4
 Door bin adjustability - Refrigerator : Yes
 Tilt-out door bins in fridge : No
 Gallon Storage : Yes
 Number of Gallon storage : 2
 No. of shelves in fridge : 7
 Motorized Shelf : No
 Material of the shelves : Glas
 Door opened indicator freezer : Yes
 Connection Rating (W) : 90
 Current (A) : 10
 Voltage (V) : 220-240
 Frequency (Hz) : 50
 Approval certificates : CE, VDE
 Door panel options : Not possible
 Installation typology : N/A
 Noise level (dB(A) re 1 pW) : 39
 Energy Star Qualified : No
 Plug type : Gardy plug w/ earthing
 Required cutout/niche size for installation (in) : x x
 Dimensions of the packed product (in) : 74.80 x 25.59 x 29.13
 Net weight (lbs) : 165
 Gross weight (lbs) : 170

Included accessories

1 x egg tray



iQ700

KS36WPI30

Stainless Steel Doors

Features

Consumption

- Energy efficiency class: A++
- Total net capacity: 346 litres
- Noise level dB(A) re 1 pW: 39

Design

- Doors Stainless Steel, side panels Inox Look
- vertical bar handle
- Internal LED lights
- Interior with metal applications

Comfort and Safety

- Water with LED light, flush with door, tap connection with Aquastop®, hose 2 m, 3/4"
- Aquastop® with lifetime warranty
- Touchcontrol- Electronic - Electronic Control
- freshSense - constant temperature by intelligent sensor technology
- Super cool function
- Acoustic warning system

Fridge Section

- Net capacity refrigeration zone: 346 l
- Active cooling via integrated fan
- AirFreshFilter
- Automatic defrost
- 7 safety glass shelves of which 5 are height adjustable,
- Multi purpose shelf
- 5 door bins, three of 1 with comfortable (EASYLIFT) and Dairy compartment

Freshness System

- 1 cont. hydrofresh with humidity control - keeps fruit and vegetables fresher for twice as long
- Pull out vegetable container

APPLIANCE DIMENSION

- Dimensions: H 187 cm x L 60 cm x D 65 cm
- Door left hinged
- 1 cont. hydrofresh - keeps fruit and vegetables up to 2 x longer fresh!
- Multi purpose shelf -variable space!
- comfortable (EASYLIFT) - always at the right height!
- Easy access shelves - easy access and everything in sight
- Internal LED lights - longlasting, efficient and perfect illumination!

iQ700
KS36WPI30
Stainless Steel Doors

Dimensioned drawings

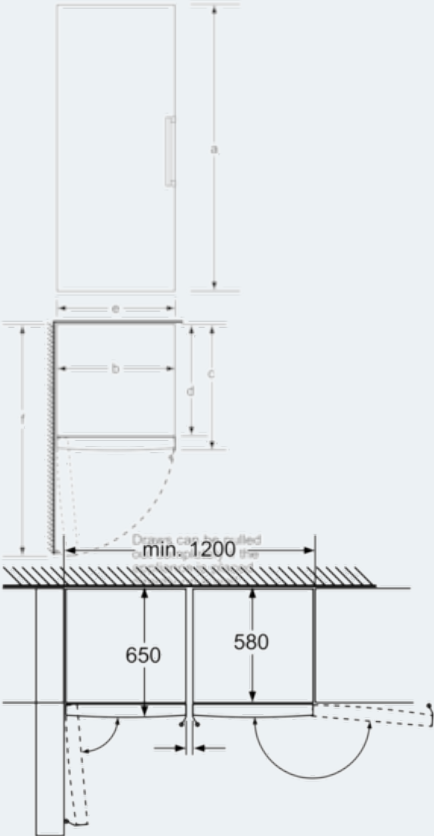

Drawers can be pulled out completely if the appliance is placed directly on a wall.
measurements in mm

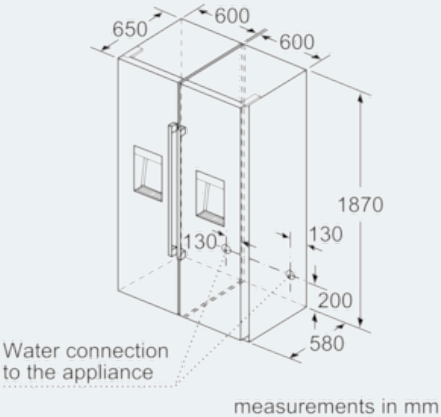

measurements in mm