

## iQ700, Built-in Fridge-Freezer, 177.5 x 56 cm KI42FP60

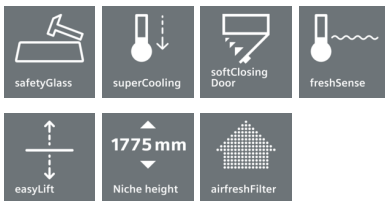

A++



iQ 700 coolConcept premium fridge with vitaFresh Boxes to keep food fresh up to 3 times longer, plus flexible easyLift shelves, in the very efficient EEC A++.

- ✓ The LED lights up the interior brightly and evenly, without dazzling.
- ✓ The superCooling button reduces the temperature for a set time, to quickly cool down fresh food items.
- ✓ The multiAlarm system notifies you visually and acoustically if the temperature goes up.
- ✓ An A++ cooling appliance works very efficiently.
- ✓ The safetyGlass shelves are of extra strong, easy-cleaning safety glass.

### Features

#### Technical data

Built-in / Free-standing : Built-in  
 Number of compressors : 1  
 Number of independent cooling systems : 2  
 Width of the product (mm) : 556  
 Height (mm) : 1772  
 Depth of the product : 545  
 Net weight (kg) : 81.287  
 Required niche size for installation (HxWxD) : 1775.0 x 560 x 550  
 Door panel options : Not possible  
 Door hinge : Right reversible  
 Number of Adjustable Shelves in fridge compartment : 3  
 Shelves for Bottles : Yes  
 Frost free system : No  
 Interior ventilator : Yes  
 Reversible Door Hinge : Yes  
 Length electrical supply cord (cm) : 230  
 Noise level (dB(A) re 1 pW) : 39  
 Multi-Flow Air Tower : No  
 Economy setting : No  
 Cold technology : 1 compressor/2 cold circuits  
 Fast cooling switch : Yes  
 Temperature Controlled Drawer : No  
 Humidity Control Drawer : No  
 Number of Door Bins - Refrigerator : 4  
 Door bin adjustability - Refrigerator : No  
 Tilt-out door bins in fridge : No  
 Gallon Storage : Yes  
 Number of Gallon storage : 1  
 No. of shelves in fridge : 7  
 Motorized Shelf : No  
 Material of the shelves : Glas, plastic  
 Door opened indicator freezer : Yes  
 Connection Rating (W) : 120  
 Current (A) : 10  
 Voltage (V) : 220-240  
 Frequency (Hz) : 50  
 Approval certificates : CE, Ukraine, VDE  
 Main colour of product : White  
 Door panel options : Not possible  
 Installation typology : Full-integrated  
 Noise level (dB(A) re 1 pW) : 39  
 Energy Star Qualified : No  
 Plug type : Gardy plug w/ earthing  
 Required cutout/niche size for installation (in) : x x  
 Dimensions of the packed product (in) : 77.95 x 24.80 x 25.98  
 Net weight (lbs) : 179  
 Gross weight (lbs) : 191

#### Included accessories

2 x egg tray



## iQ700, Built-in Fridge-Freezer, 177.5 x 56 cm KI42FP60

### Features

#### General Information

- Energy efficiency class: A+++ (133 kWh per year). Actual energy consumption will depend on how the appliance is used and where it is located.
- 2 0degree moist humidity container with humid capacity and base unit on Telescopic-Rails
- Total net capacity: 302 litres

#### Comfort and Safety

- LED electronic TouchControl
- Automatic defrost
- Super cool function
- Acoustic warning system

#### Fridge Section

- 7 safety glass shelves of which 3 are height adjustable, 1 Easy Lift Glass Shelf
- 4 full extension storage trays
- 1 Divider Box
- Bottle rack
- 4 door bins, thereof 1 extra deep with divider and 3 with comfortable (EASYLIFT)
- Dairy compartment
- Internal LED lights on the both sides
- 25 l Vegetable Container with humidity control, wave bottom on full extendend telescopic rails
- Internal LED lights

#### Design

- Soft Close Door
- Door right hinged, reversible
- fixed hinge, Sliding Hinge
- Complete ventilation trough plinth

## iQ700, Built-in Fridge-Freezer, 177.5 x 56 cm KI42FP60

### Dimensioned drawings

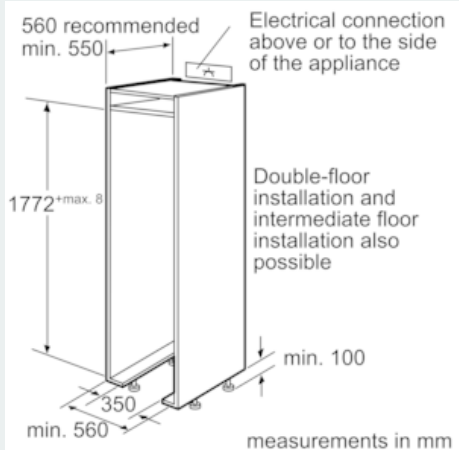
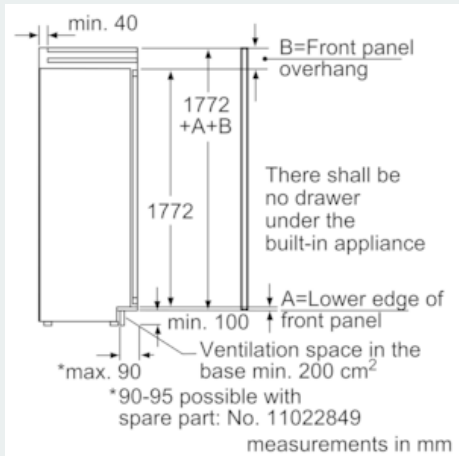
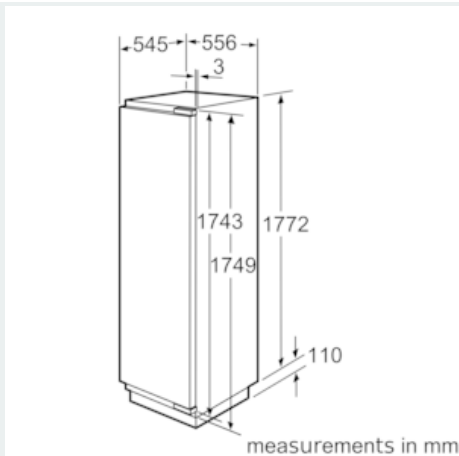

### measurements in mm Recommended gap dimensions for flat hinges

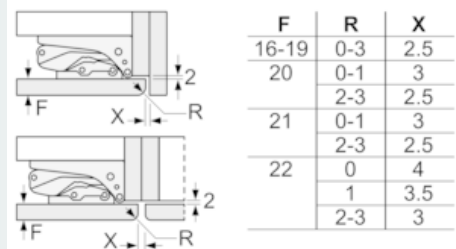

The gap dimensions recommended in the table must be adhered to in order to ensure that appliance doors do not collide with anything when they are opened, and to avoid causing damage to kitchen units.