

## iQ100, Built-in Full Fridge, 88 x 56 cm KI18RV51



### Included accessories

1 x egg tray

iQ 300 built-in fridge freezer for crisper fruit and vegetables longer thanks to the drawer with corrugated bottom.

- ✓ The LED lights up the interior brightly and evenly, without dazzling.
- ✓ The safetyGlass shelves are of extra strong, easy-cleaning safety glass.
- ✓ A+ energy class refrigerator consumes %20 less energy than A energy class.

### Features

#### Technical data

Built-in / Free-standing : Built-in  
 Number of compressors : 1  
 Number of independent cooling systems : 1  
 Width of the appliance : 541  
 Height (mm) : 874  
 Depth of the product : 542  
 Net weight (kg) : 32.919  
 Required niche size for installation (HxWxD) : 880 x 560 x 550  
 Door panel options : Not possible  
 Door hinge : Right reversible  
 Number of Adjustable Shelves in fridge compartment : 3  
 Shelves for Bottles : No  
 Frost free system : No  
 Interior ventilator : No  
 Reversible Door Hinge : Yes  
 Length electrical supply cord (cm) : 230  
 Noise level (dB(A) re 1 pW) : 34  
 Multi-Flow Air Tower : No  
 Economy setting : No  
 Cold technology : 1 compressor/1 cold circuit  
 Fast cooling switch : No  
 Temperature Controlled Drawer : No  
 Humidity Control Drawer : No  
 Number of Door Bins - Refrigerator : 4  
 Door bin adjustability - Refrigerator : No  
 Tilt-out door bins in fridge : Yes  
 Gallon Storage : Yes  
 Number of Gallon storage : 4  
 No. of shelves in fridge : 4  
 Motorized Shelf : No  
 Material of the shelves : Glas, plastic, support grid, wood  
 Door opened indicator freezer : No  
 Connection Rating (W) : 90  
 Fuse protection (A) : 10  
 Voltage (V) : 220-240  
 Frequency (Hz) : 50  
 Energy consumption annual (kWh/annum) - NEW (2010/30/EC) : 122.00  
 Refrigerator Net capacity (l) - NEW (2010/30/EC) : 150  
 Freezer Net capacity (l) - NEW (2010/30/EC) : 0  
 Frost free system : No  
 Freezing capacity (kg/24h) - NEW (2010/30/EC) : 0  
 Approval certificates : CE, VDE  
 Main colour of product : N/A  
 Door panel options : Not possible  
 Installation typology : Full-integrated  
 Noise level (dB(A) re 1 pW) : 34  
 Energy Star Qualified : No  
 Plug type : Gardy plug w/ earthing  
 Required cutout/niche size for installation (in) : x x  
 Dimensions of the packed product (in) : 37.40 x 24.01 x 24.80  
 Net weight (lbs) : 73.000  
 Gross weight (lbs) : 78.000



## iQ100, Built-in Full Fridge, 88 x 56 cm KI18RV51

### Features

#### General Information

- Energy efficiency class: A+ (122 kWh per year). Actual energy consumption will depend on how the appliance is used and where it is located.
- Total net capacity: 150 litres

#### Comfort and Safety

- Mechanical control
- Automatic defrost

#### Fridge Section

- 4 safety glass shelves of which 3 are height adjustable
- 1 vegetable container
- with wave bottom
- 4 door trays
- Internal LED lights

#### Design

- Door right hinged, reversible
- fixed hinge, Sliding Hinge
- Easy clean interior

**iQ100, Built-in Full Fridge, 88 x 56 cm  
KI18RV51**

Dimensioned drawings

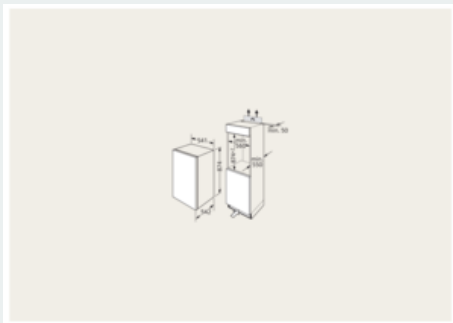
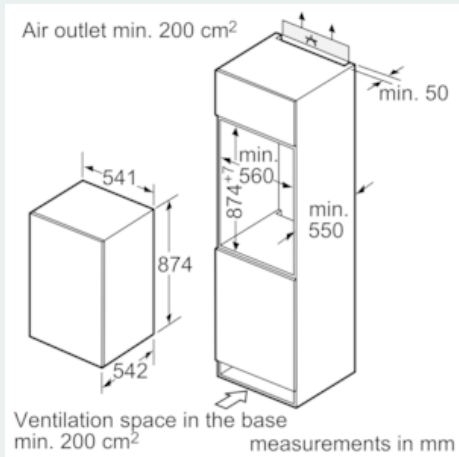

measurements in mm  
Recommended gap dimensions for flat hinges

	F	R	X
16-19	0-3	2.5	
	20	0-1	3
21	2-3	2.5	
	21	0-1	3
22	2-3	2.5	
	0	4	
	1	3.5	
	2-3	3	

The gap dimensions recommended in the table must be adhered to in order to ensure that appliance doors do not collide with anything when they are opened, and to avoid causing damage to kitchen units.