

iQ500, Side-by-Side Fridge, 178.7 x 90.8 cm, Inox-easyclean KA93GAI30N



A++

- ✓ Ice & Water dispenser with tap connection: Refreshment made easy.
- ✓ noFrost – Never defrost your freezer again.
- ✓ Plenty of space for weekly shopping thanks to extra high capacity.
- ✓ superCooling: Fast cooling for your fresh food.
- ✓ multiAirflow: Consistent cooling for longer freshness.



Design:	Free-standing
Number of compressors:	1
Number of independent cooling systems:	1
Width of the appliance:	908 mm
Height:	1787 mm
Depth:	707 mm
Net weight:	111.8 kg
Min. required niche size for installation (HxWxD):	mm
Door panel options:	Not possible
Door opening:	left and right
Number of Adjustable Shelves in fridge compartment:	0
Shelves for Bottles:	No
Frost free system:	Freezer
Interior ventilator:	No
Reversible Door Hinge:	No
Length electrical supply cord:	170.0 cm
Noise level:	42 dB(A) re 1 pW
Connection rating:	240 W
Fuse protection:	10 A
Voltage:	220-240 V
Frequency:	50 Hz
Energy efficiency:	
Energy consumption annual - NEW (2010/30/EC):	343.00 kWh/annum
Refrigerator Net capacity - NEW (2010/30/EC):	366 l
Freezer Net capacity - NEW (2010/30/EC):	165 l
Energy consumption:	kWh
Freezing capacity) - NEW (2010/30/EC):	13 kg/24h
Freezing capacity:	kg
Storage Period in Event of Power Failure (h):	8 h
Included accessories:	1 x connection hose, 1 x egg tray



**iQ500, Side-by-Side Fridge, 178.7
x 90.8 cm, Inox-easyclean
KA93GAI30N**

Measurements in mm

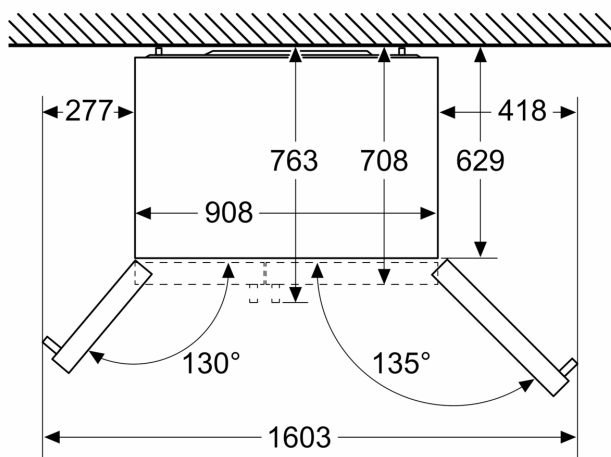

Measurements in mm

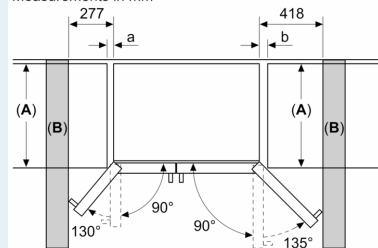

A	a	b
≤ 600	50	50
600 < A ≤ 650	50	50
650 < A ≤ 700	53	96
> 700	277	418

A: Kitchen cabinet or worktop depth

B: Wall
Drawers can be pulled out with door open to 90°

Drawers can be taken out with door completely opened

measurements in mm

