

iQ700 GS36DPI20 Upright Freezer



A+



Included accessories

3 x cold accumulator

iQ 700 premium freezer with iceDispenser for ice cubes on demand and innovative noFrost technology for no more defrosting.

- ✓ IceDispenser with tap connection - cubes and crushed ice any time. With Aqua Stop.
- ✓ noFrost technology prevents icing and frosting so you never have to defrost again.
- ✓ Control all functions easily and precisely with just a soft touch, using touchControl electronics.
- ✓ All freezer drawers and glass shelves can be removed easily. varioZone lets you organize the space flexibly.
- ✓ The LED lights up the interior brightly and evenly, without dazzling.
- ✓ Cooling appliances with 90° door opening angle can be placed flush against any wall or in any niche.

Features

Technical data

Product category : Upright freezer
 Built-in / Free-standing : Free-standing
 Color / Material body : Chrome Inox-metallic
 Frost free system : Fridge and freezer
 Climate class : SN-T
 Door panel options : Not possible
 Width of the product (mm) : 600
 Depth of the product : 650
 Dimensions of the packed product (HxWxD) (mm) : 1900 x 740 x 650
 Warning signal / malfunction : visual and audible
 Number of drawers/baskets (Stck) : 5
 Number of freezing flaps (Stck) : 2
 Lockable door : No
 Thermometer freeze section : Digital
 Light : Yes
 Length electrical supply cord (cm) : 230
 Door hinge : Right
 Net weight (kg) : 87.005
 Gross weight (kg) : 89.0
 Multi-Flow Air Tower : Yes
 Number of compressors : 1
 Number of independent cooling systems : 1
 Economy setting : No
 Fast freezing switch : Yes
 Number of Door Bins - Freezer : 0
 Number of shelves - Freezer : 0
 Shelf Material - Freezer : Safety glass
 Reversible Door Hinge : No
 Connection Rating (W) : 90
 Current (A) : 10
 Frequency (Hz) : 50
 Approval certificates : CE, VDE
 Door panel options : Not possible
 Installation typology : N/A
 Noise level (dB(A) re 1 pW) : 42
 Energy Star Qualified : No
 Approval certificates : CE, VDE
 Plug type : Gardy plug w/ earthing
 Required cutout/niche size for installation (in) : x x
 Dimensions of the packed product (in) : 74.80 x 25.59 x 29.13
 Net weight (lbs) : 192
 Gross weight (lbs) : 196



iQ700

GS36DPI20

Upright Freezer

Features

Consumption

- Energy Efficiency Class: A+
- Total net capacity: 210 litres
- Noise level dB(A) re 1 pW: 42

Design

- Doors Stainless Steel, side panels Inox Look
- vertical bar handle
- LED
- Interior with metal applications

Comfort and Safety

- Frost Free - never again defrosting
- Ice maker, cubes or crushed ice, with LED light, flush with door, tap connection with Aquastop®, hose 2 m, 3/4"
- Aquastop® with lifetime warranty
- Touchcontrol-Electronic - 7 segment electronic control
- Optic and acoustic Warning System
- Multi-Alarm-System with memory function and "Door open" warning tone
- freshSense - constant temperature by intelligent sensor technology
- Super freezing with automatic switch off
- easy door opening with Air Channel System

Freezer Section

- Net freezer capacity 210 litres
- Freezing capacity: 16 kg in 24 hours
- Multi Airflow-System
- Storage time in power failure: 17 Hours
- 2 compartments with glass shelves and transparent hinge
- Safety glass
- 5 transparent freezer drawers, whereof 1 extra large Big Box drawer
- Calendar frozen food
- Stainless Steel Doors

APPLIANCE DIMENSION

- Dimensions: H 187 cm x L 60 cm x D 65 cm
- Frost Free - never again defrosting
- LED - bright and efficient, an appliance lifetime!
- Automatic ice cube maker, Crushed ice - easy refilling and always fresh ice!
- 1 - extra space for extra large frozen food!

iQ700
GS36DPI20
Upright Freezer

Dimensioned drawings

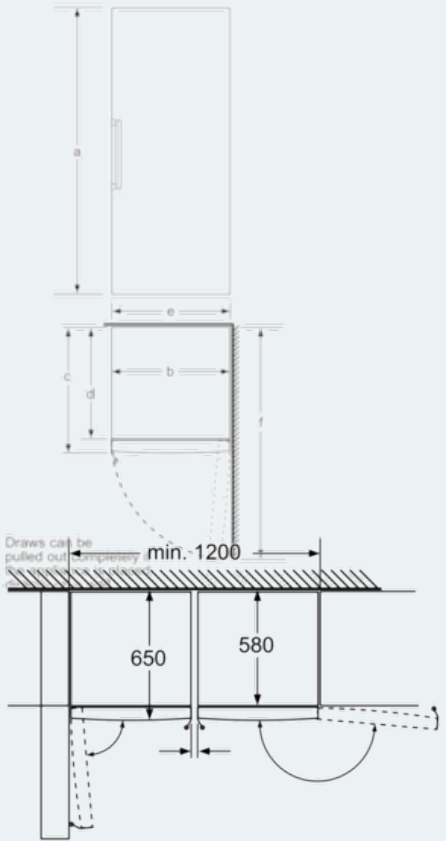

Drawers can be pulled out completely if the appliance is placed directly on a wall.
measurements in mm

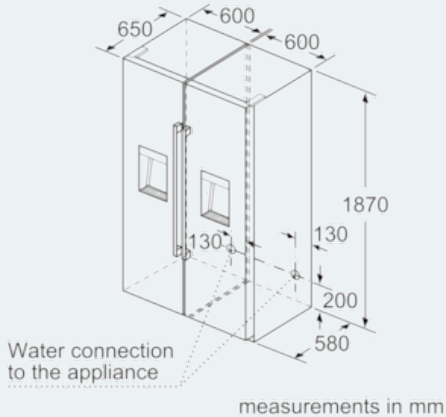

measurements in mm