

**Series 6, Built-in Freezer, 177.2 x 55.8 cm, flat hinge
GIN81AEF0U**



NoFrost Upright Freezer with 235 l gross capacity, and 7 compartments provides extra space to store your frozen food.

- **A++ energy class refrigerator consumes 40% less energy than A energy class.**
- **No Frost: You'll never have to defrost your freezer again.**
- **Intelligent Inverter Technology ensures a stable temperature control and efficient performance.**
- **Super Freezing function: Protects frozen food from defrosting.**
- **Big Box drawer: for stacking storage containers or for large frozen food items.**

Energy Efficiency Class (Regulation (EU) 2017/1369): F
Lockable door: No
Door panel options: Not possible
Thermometer freeze section: Digital
Product category: Upright freezer
Width of the appliance: 558 mm
Light: No
Built-in / Free-standing: Built-in
Depth: 545 mm
Length electrical supply cord: 230.0 cm
Dimensions of the packed product (HxWxD):	... 1840 x 610 x 640 mm
Door hinge: Left reversible
Frost free system: Fridge and freezer
Required niche size for installation (HxWxD):	... 1775 x 560 x 550 mm
Net weight: 64.3 kg
Warning signal / malfunction: Both visual and audible
Gross weight: 69.0 kg
Defrost: Automatic
Cover door installation system: Fixed-mounted
Number of drawers/baskets (Stck): 5
Number of freezing flaps (Stck): 2
Connection rating: 120 W
Fuse protection: 10 A
Frequency: 50 Hz
Included accessories: 2 x cold accumulator, 1 x ice cube tray





**Series 6, Built-in Freezer, 177.2 x
55.8 cm, flat hinge
GIN81AEF0U**

NoFrost Upright Freezer with 235 l gross capacity, and 7 compartments provides extra space to store your frozen food.

Main Characteristics

- Frost free
- Gross capacity, total: 235 l
- Total net capacity: 211 litres
- Energy efficiency class: A++
- Noise level dB(A) re 1 pW: 36
- Dimensions: H 177.2 cm x L 55.8 cm x D 54.5 cm

Freezer

- Net freezer capacity 211 litres
- Freezing capacity: 20 kg in 24 hours
- Storage time in power failure: 22 Hours
- 5 freezer drawers, incl. 1 Big Box
- Manual/automatic activation

Comfort and Safety

- Acoustic warning system
- no handle
- Door left hinged, reversible

Technical Information

- Gross capacity, total: 235 l
- **** freezer 235 l (-18°C and below)
- Energy efficiency class: A++ (243 kWh per year). Actual energy consumption will depend on how the appliance is used and where it is located.
- Climate Class SN-T
- Height adjustable front feet, roles in the back
- Connected load 120 W
- Rated Voltage 220 - 240 V
- Appliance Dimensions (H x W x D): 177.2 cm x 55.8 cm x 54.5 cm

Series 6, Built-in Freezer, 177.2 x 55.8 cm, flat hinge
GIN81AEF0U

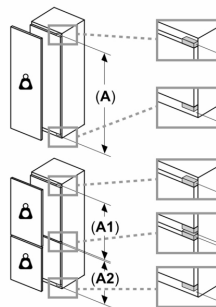
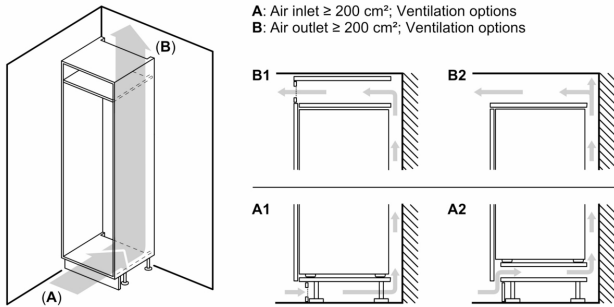

Maximal permissible weight of the unit fronts

Fitted unit fronts that exceed the permissible weight may cause damage and result in functional impairment of the hinges

Δ : Weight
 A: Appliance door height including hinges in mm

B: Undamped hinge, unit front in kg

C: Damped hinge, unit front in kg

D: Additional possible load in kg with heavy load kit

A	B	C	D
1500-1750	22	22	
720-1400	19	19	B+5 / C+5
A1	15	19	
A2	15	19	

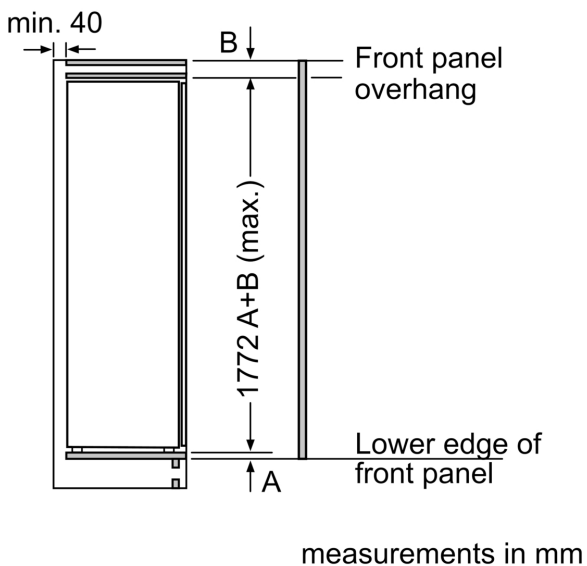
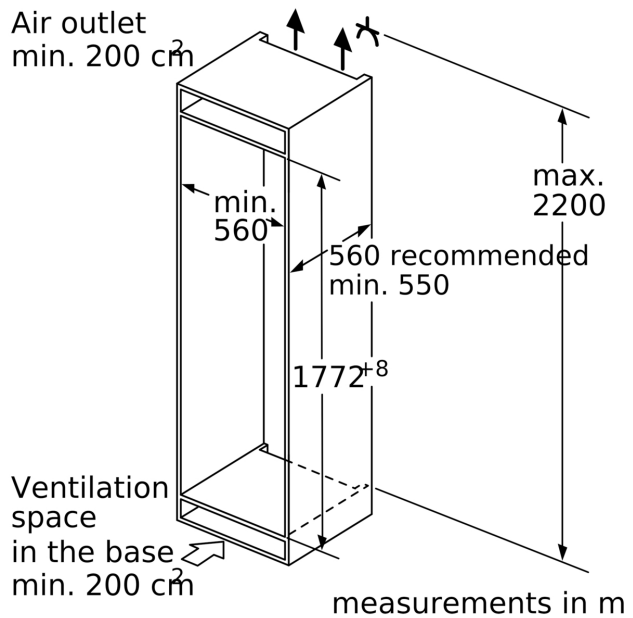
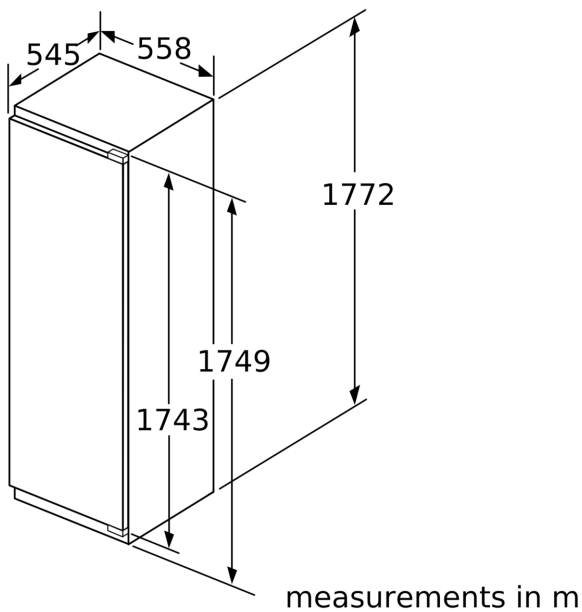

Maximal permissible weight of the unit fronts

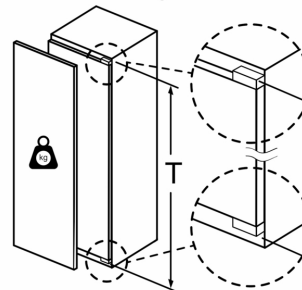

Fitted kitchen unit doors that exceed the permissible weight may cause damage and result in functional impairment of the hinges.

T: Includes height of appliance door	undamped hinge, Door in kg:	damped hinge, Door in kg:
Hinges in mm:		
1500-1750	22	22

measurements in mm
 Recommended gap dimensions for flat hinges

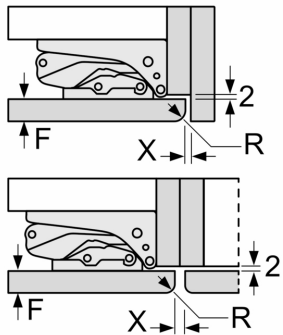

F	R	X
16-19	0-3	2.5
20	0-1	3
	2-3	2.5
21	0-1	3
	2-3	2.5
22	0	4
	1	3.5
	2-3	3

The gap dimensions recommended in the table must be adhered to in order to ensure that appliance doors do not collide with anything when they are opened, and to avoid causing damage to kitchen units.