

**Series 6, Built-in Freezer, 177.2 x 55.8 cm, flat hinge  
GIN81AEF0**



**A++**

**The NoFrost freezer with electronic temperature control: set the target temperature precisely and easily.**

- **VarioZone:** more flexibility due to variable-use glass shelves and drawers in the freezer compartment.
- **NoFrost:** never defrost again, thanks to perfect protection from ice formation - that saves time and effort.
- **Big Box drawer:** for stacking storage containers or for large frozen food items.



1 x ice cube tray

KSZB0S00 Heavy-duty hinge support

Energy Efficiency Class (Regulation (EU) 2017/1369):	..... F
Average annual energy consumption in kilowatt hour per year (kWh/a) (EU) 2017/1369:	.....294 kWh/annum
Sum of volume of frozen compartments (EU 2017/1369):	..... 212 l
Airborne acoustical noise emissions :	.....36 dB(A) re 1 pW
Airborne acoustical noise emission class (EU 2017/1369):	..... C
Lockable door:	..... No
Door panel options:	..... Not possible
Thermometer freeze section:	..... Digital
Product category:	..... Upright freezer
Width of the appliance:	.....558 mm
Light:	..... No
Built-in / Free-standing:	..... Built-in
Depth:	.....545 mm
Length electrical supply cord:	..... 230.0 cm
Dimensions of the packed product (HxWxD):	... 1840 x 610 x 640 mm
Door hinge:	..... Left reversible
Frost free system:	..... Fridge and freezer
Net weight:	.....65.6 kg
Warning signal / malfunction:	..... Both visual and audible
Gross weight:	..... 70.3 kg
Defrost process:	.....Automatic
Cover door installation system:	..... Fixed-mounted
Number of drawers/baskets (Stck):	..... 5
Number of freezing flaps (Stck):	..... 2
Connection rating:	..... 120 W
Fuse protection:	.....10 A
Frequency:	..... 50 Hz
Included accessories:	..... 1 x ice cube tray



**Series 6, Built-in Freezer, 177.2 x  
55.8 cm, flat hinge  
GIN81AEF0**

**The NoFrost freezer with electronic  
temperature control: set the target  
temperature precisely and easily.**

---

**Consumption**

**Comfort and Safety**

- Frost free - never again defrosting
- Flat hinge
- 7 segment electronic control
- 1 compressor/1 cold circuit
- Manual/automatic activation
- freshSense - constant temperature by intelligent sensor technology
- Acoustic warning system, Optical warning system

**Freezer Section**

- 5 transparent freezer drawers, whereof 2 extra large Big Box drawer

**Technical Information**

- Door left hinged, reversible
- Connected load 120 W
- Rated Voltage 220 - 240 V

**APPLIANCE DIMENSION**

- Niche Dimension H X W x D: 177.5 cm cm x 56 cm x 55 cm
- Dimensions: H 177.2 cm x L 55.8 cm x D 54.5 cm

**Accessories**

- 1 x ice cube tray

**Country Specific Options**

- Based on the results of the standard 25-hour test. Actual consumption depends on usage/position of the appliance.

**General Information**

**Series 6, Built-in Freezer, 177.2 x 55.8 cm, flat hinge  
GIN81AEF0**

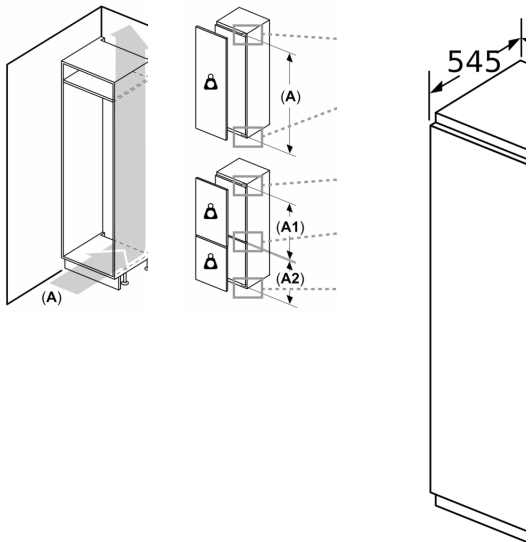

Air outlet  
min. 200

Ventilatio  
space  
in the bas  
min. 200

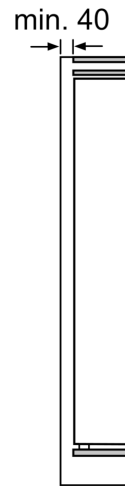

Maximal per

measurem  
Recommen

Fitted kitchen  
weight may c  
impairment c

T: Includes I  
of appliance  
Hinges in m  
1500-1

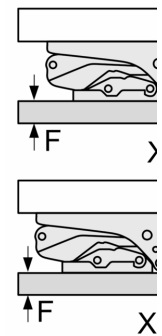

The gap di  
in the table  
to ensure th  
collide with  
and to avoi