

## iQ700, Built-in Freezer, 177.2 x 55.6 cm GI38NP60



A++



Premium: iQ 700 freezer in energy-saving efficiency class A++, with noFrost technology so you never have to defrost again.

- ✓ noFrost technology prevents icing and frosting so you never have to defrost again.
- ✓ The LED lights up the interior brightly and evenly, without dazzling.
- ✓ The bigBox offers plenty of space to store and stack large frozen items efficiently.
- ✓ The multiAlarm system notifies you visually and acoustically if the temperature goes up.
- ✓ An A++ cooling appliance works very efficiently.
- ✓ The superFreezing button reduces the temperature for a set time, to quickly freeze newly added food items.

### Features

#### Technical data

Product category : Upright freezer  
 Built-in / Free-standing : Built-in  
 Color / Material body : White  
 Frost free system : Fridge and freezer  
 Climate class : SN-T  
 Door panel options : Not possible  
 Width of the product (mm) : 556  
 Depth of the product : 545  
 Dimensions of the packed product (HxWxD) (mm) : 1980 x 660 x 630  
 Warning signal / malfunction : visual and audible  
 Cover door installation system : Fixed-mounted  
 Number of drawers/baskets (Stck) : 5  
 Number of freezing flaps (Stck) : 2  
 Lockable door : No  
 Thermometer freeze section : Digital  
 Light : Yes  
 Length electrical supply cord (cm) : 230  
 Door hinge : Left reversible  
 Net weight (kg) : 78.319  
 Gross weight (kg) : 83.8  
 Multi-Flow Air Tower : No  
 Number of compressors : 1  
 Number of independent cooling systems : 1  
 Economy setting : No  
 Fast freezing switch : No  
 Number of Door Bins - Freezer : 0  
 Door bin adjustability - Freezer : No  
 Tilt-out door bins in freezer : No  
 Number of shelves - Freezer : 0  
 Door bin adjustability - Freezer : No  
 Shelf Material - Freezer : Plastic  
 Reversible Door Hinge : Yes  
 Connection Rating (W) : 120  
 Current (A) : 10  
 Frequency (Hz) : 50  
 Approval certificates : CE, Ukraine, VDE  
 Main colour of product : White  
 Door panel options : Not possible  
 Installation typology : Full-integrated  
 Noise level (dB(A) re 1 pW) : 42  
 Energy Star Qualified : No  
 Approval certificates : CE, Ukraine, VDE  
 Plug type : Gardy plug w/ earthing  
 Required cutout/niche size for installation (in) : x x  
 Dimensions of the packed product (in) : 77.95 x 24.80 x 25.98  
 Net weight (lbs) : 173  
 Gross weight (lbs) : 185

#### Included accessories

- 2 x cold accumulator
- 1 x ice cube tray



**iQ700, Built-in Freezer, 177.2 x 55.6  
cm  
GI38NP60**

#### Features

##### General Information

- Energy efficiency class: A++ (242 kWh per year). Actual energy consumption will depend on how the appliance is used and where it is located.
- Total net capacity: 210 litres

##### Comfort and Safety

- Frost Free - never again defrosting
- LED electronic control
- Super freezing with automatic switch off
- Automatic defrost
- Optical and acoustic warning System

##### Freezer Section

- 2 hinged freezer compartments with transparent front
- Calendar frozen food
- Safety glass shelves between freezer drawers
- LED Lighting

##### Design

- Soft Close Door
- Door left hinged, Reversible
- Door opening aid

## iQ700, Built-in Freezer, 177.2 x 55.6 cm GI38NP60

### Dimensioned drawings

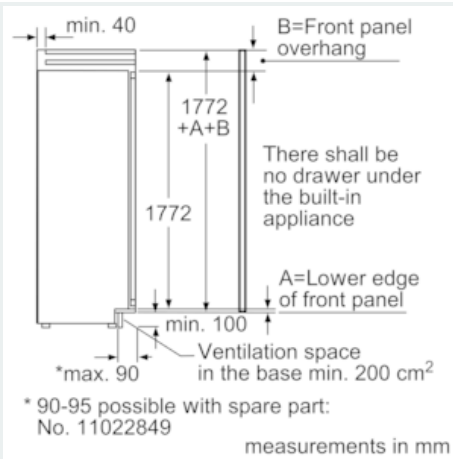

### measurements in mm Recommended gap dimensions for flat hinges

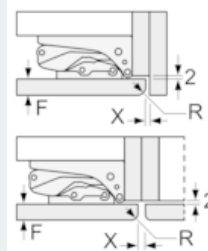

F	R	X
16-19	0-3	2.5
20	0-1	3
21	2-3	2.5
	0-1	3
22	2-3	2.5
	0	4
	1	3.5
	2-3	3

The gap dimensions recommended in the table must be adhered to in order to ensure that appliance doors do not collide with anything when they are opened, and to avoid causing damage to kitchen units.

