

iQ700, Domino Gas Hob, 30 cm, Ceramic, Black ER3A6AB70



Gas cooktop with stepFlame Technology for precise flame control in nine steps.

- ✓ stepFlame Technology: precise heat control with nine different flame steps.
- ✓ Dishwasher proof pan supports are extremely easy to remove and clean in the dishwasher. Cut down the time you spend cleaning the hob.
- ✓ High-quality materials and workmanship – continuous cast-iron pan supports.
- ✓ Design burner – extremely flat in comparison to standard burner.
- ✓ Extremely heat-resistant and easy to clean – the modern glass ceramic surface.

Product name/family:Vario/Domino gas hob w control
 Product name/family:Vario/Domino gas hob w control
 Design: Built-in
 Design: Built-in
 Type of heating: Gas
 Type of heating: Gas
 Total number of positions that can be used at the same time: 1
 Total number of positions that can be used at the same time: 1
 Min. required niche size for installation (HxWxD): 45 x 270 x 490-500 mm
 Min. required niche size for installation (HxWxD): 45 x 270 x 490-500 mm
 Width of the appliance: 302 mm
 Width of the appliance: 302 mm
 Dimensions: 59 x 302 x 520 mm
 Dimensions: 59 x 302 x 520 mm
 Dimensions of the packed product (HxWxD): ... 190 x 380 x 580 mm
 Dimensions of the packed product (HxWxD): ... 190 x 380 x 580 mm
 Net weight: 8.1 kg
 Net weight: 8.1 kg
 Gross weight: 9.0 kg
 Gross weight: 9.0 kg
 Residual heat indicator: No
 Residual heat indicator: No
 Location of control panel: Front
 Location of control panel: Front
 Basic surface material: Ceramic
 Basic surface material: Ceramic
 Color of surface: Black, Alu, brushed
 Color of surface: Black, Alu, brushed
 Color of frame: Black
 Color of frame: Black
 Length electrical supply cord: 100.0 cm
 Length electrical supply cord: 100.0 cm
 EAN code: 4242003925652
 EAN code: 4242003925652
 Gas connection rating: 6100 W
 Gas connection rating: 6100 W
 Fuse protection: 3 A
 Fuse protection: 3 A
 Voltage: 220-240 V
 Voltage: 220-240 V
 Frequency: 50; 60 Hz
 Frequency: 50; 60 Hz
 Included accessories: 1 x WOK attachment ring

1 x WOK attachment ring

HZ298105 Simmer plate
 HZ298113 Small pot support
 HZ394301 Connecting strip



iQ700, Domino Gas Hob, 30 cm, Ceramic, Black ER3A6AB70

Design

- ceramic glass surface, black
- Facette front, rear, side profiles, aluminium, brushed
- cast iron pan support
- BSH flat burner: elegant burner design with less pieces

Comfort & Convenience

- Step valve 9 steps: precisely adjust the flame in nine defined and repeatable levels.
- yes: clean without effort in the dishwasher.
- Sword Knobs: easily access knobs in front with strong grip for effortless turning.
- Ignition via control dials: just push and turn the knob to ignite the flame.

Burners and power

- 1 PC
- Including 1 Dual Wok burner: use an extra wide power range, separately controlling two flame rings.
- Center front: Wok burner up to 6.1 KW (depending on gas type)

Safety

- Flame failure safety device: prevents unwanted gas flow when flame goes out.

Installation (gas types & measurements)

- Usable for: Nat gas L/LL G25/20mbar(DE)
- NG H/E 20mbar, E+ 20/25mbar Natural gas H 25 mbar (HU) Natural gas L 25 mbar (NL) Liquid gas G30,31 28-30/37mbar Liquid gas G30 37 mbar (PL) Liquid gas 50 mbar
- Factory set for connection to mains gas
- Nozzle set for LPG jets (28-30/37mbar) included. Nozzles for all other gas types can be ordered via the customer service. For nozzle change, please contact the customer service.
- Dimensions of the product (HxWxD mm): 59 x 302 x 520
- Required niche size for installation (HxWxD mm) : 45 x 270 x (490 - 502)
- Min. worktop thickness: 30 mm
- Power cord: 1 m
- Connected load: 6.1 KW

Accessories

- WOK attachment ring included

iQ700, Domino Gas Hob, 30 cm,
Ceramic, Black
ER3A6AB70

Measurements in mm

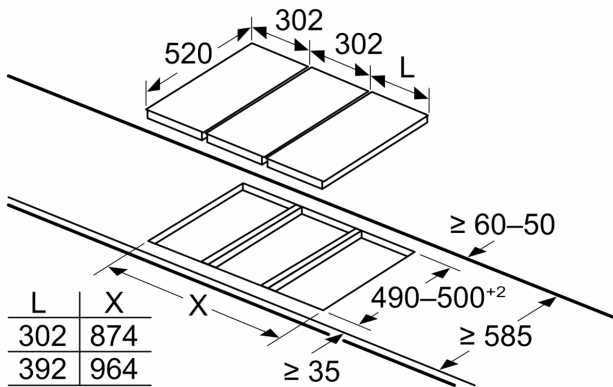

If two or more elements are installed right next to one another, one or several installation kits are required (2 elements 1 installation kit, 3 elements 2 installation kits, etc.)

measurements in mm

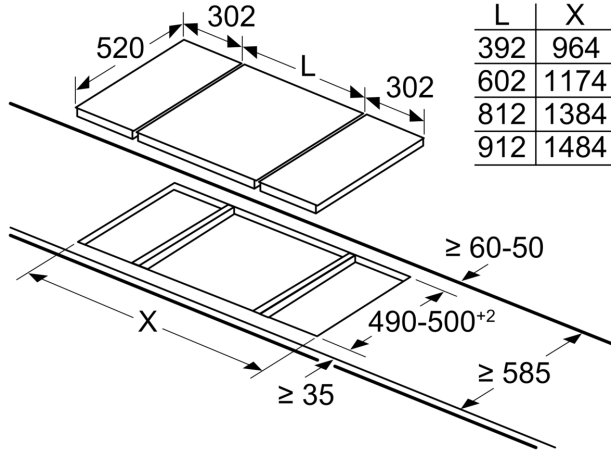

When installing two Domino units right next to a hob, two assembly kits (HZ394301) are required.

measurements in mm

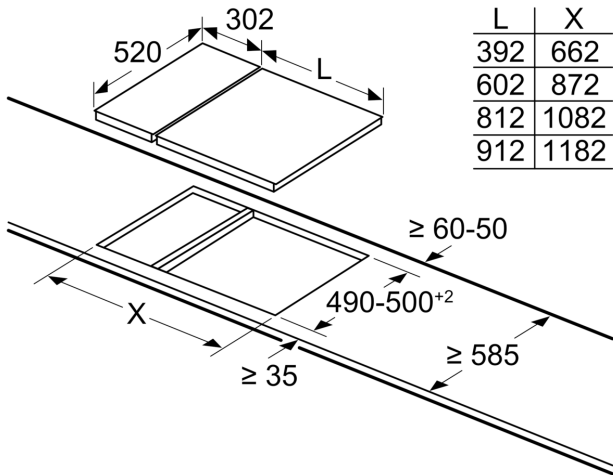

When installing a Domino unit right next to a hob, an assembly kit (HZ394301) is required.

Measurements in mm

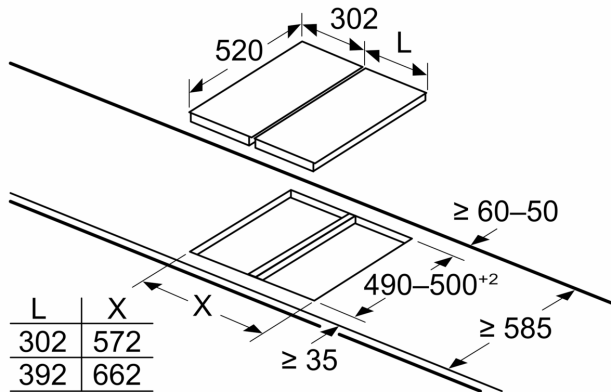

If two or more elements are installed right next to one another, one or several installation kits are required (2 elements 1 installation kit, 3 elements 2 installation kits, etc.)

measurements in mm
 Assembly kit (HZ394301) for Domino

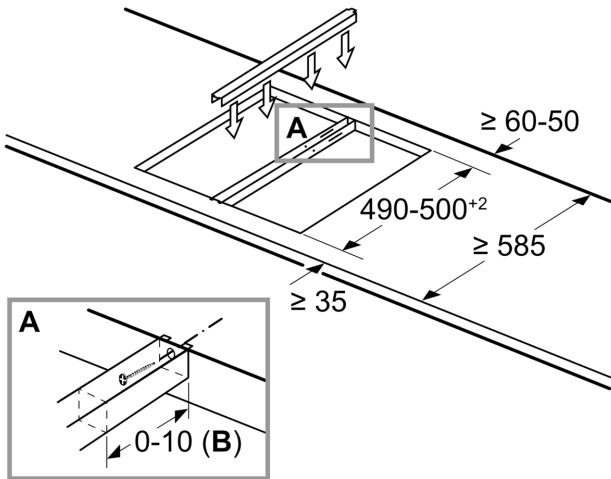

B: Dependent on the cut-out depth

measurements in mm
 Domino combination options with corresponding
 appliance and cut-out dimensions

Width category:	30	40	60	70	80	90
Appliance width:	302	392	602	710	812	912
	A	B	C	D	L	X
2x30	302	302	-	-	604	572
1x30, 1x40	302	392	-	-	694	662
1x30, 1x60	302	602	-	-	904	872
1x30, 1x70*	302	710	-	-	1012	980
1x30, 1x80	302	812	-	-	1114	1082
1x30, 1x90	302	912	-	-	1214	1182
2x40	392	392	-	-	784	752
1x40, 1x60	392	602	-	-	994	962
1x40, 1x70*	392	710	-	-	1102	1070
1x40, 1x80	392	812	-	-	1204	1172
1x40, 1x90	392	912	-	-	1304	1272
3x30	302	302	302	-	906	874
2x30, 1x40	302	302	392	-	996	964
2x30, 1x60	302	302	602	-	1206	1174
2x30, 1x70*	302	302	710	-	1314	1282
2x30, 1x80	302	302	812	-	1416	1384
2x30, 1x90	302	302	912	-	1516	1484
1x30, 2x40	302	392	392	-	1086	1054
1x30, 1x40, 1x60	302	392	602	-	1296	1264
1x30, 1x40, 1x70*	302	392	710	-	1404	1372
1x30, 1x40, 1x80	302	392	812	-	1506	1474
1x30, 1x40, 1x90	302	392	912	-	1606	1574
3x40	392	392	392	-	1176	1144
2x40, 1x60	392	392	602	-	1386	1354
4x30	302	302	302	302	1208	1176
3x30, 1x40	302	302	302	392	1298	1266
2x30, 2x40	302	302	392	392	1388	1356
1x30, 3x40	302	392	392	392	1478	1446
1x30, 1x75	302	750	-	-	1052	1016
1x40, 1x75	392	750	-	-	1142	1106
2x30, 1x75	302	302	750	-	1354	1318
1x30, 1x40, 1x75	302	392	750	-	1444	1408

* Not possible with 70 cm induction hob

Measurements in mm
 Picture for the table Domino combination possibilities with corresponding devices and
 cutout dimensions

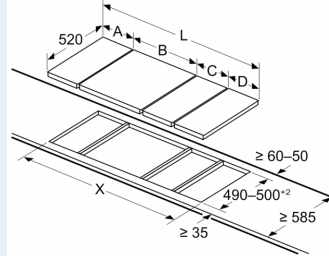

If two or more elements are installed right next to one another, one or several installation kits are required (2 elements 1 installation kit, 3 elements 2 installation kits, etc.)

Cutout dimension (X) depending on the combination (see combination table)

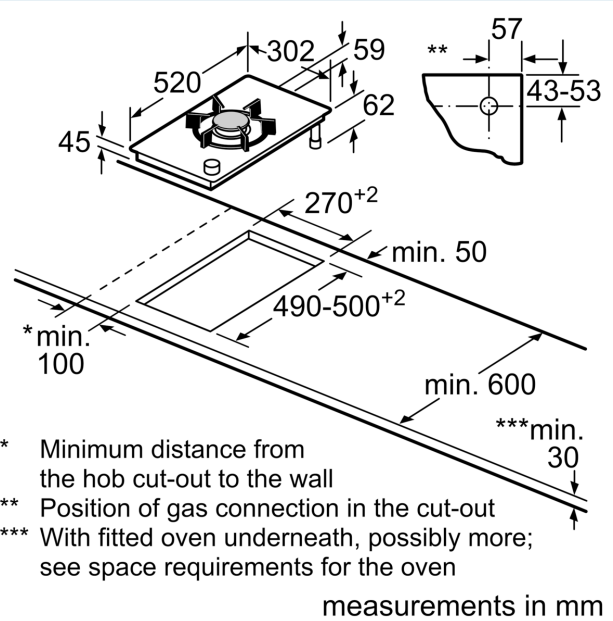

* Minimum distance from the hob cut-out to the wall

** Position of gas connection in the cut-out

*** With fitted oven underneath, possibly more; see space requirements for the oven

measurements in mm