

Serie | 2, built-under fridge, 82 x 60 cm
KUR15A50NE



Included accessories
 1 x egg tray

- **LED light:** illuminates the refrigerator evenly without glare, for the life of the appliance.
- Egg Rack

Technical data

Number of compressors :	1
Number of independent cooling systems :	1
:	598
Height (mm) :	820
:	548
Net weight (kg) :	34.095
Required niche size for installation (HxWxD) :	820 x 600 x 550
Door panel options :	Possible but accessory
:	Right reversible
Number of Adjustable Shelves in fridge compartment :	2
Shelves for Bottles :	No
Frost free system :	No
Interior ventilator :	No
Reversible Door Hinge :	Yes
Length electrical supply cord (cm) :	230
:	38
Multi-Flow Air Tower :	No
Economy setting :	No
Cold technology :	1 compressor/1 cold circuit
Fast cooling switch :	No
Temperature Controlled Drawer :	No
Humidity Control Drawer :	No
Number of Door Bins - Refrigerator :	3
Door bin adjustability - Refrigerator :	No
Tilt-out door bins in fridge :	Yes
Gallon wide door bins :	Yes
Number of Gallon storage :	1
No. of shelves in fridge :	3
Motorized Shelf :	No
Material of the shelves :	Glas, plastic
Door opened indicator freezer :	No
:	90
Current (A) :	10
Voltage (V) :	220-240
Frequency (Hz) :	50
Energy consumption annual (kWh/annum) - NEW (2010/30/EC) :	119.00
Refrigerator Net capacity (l) - NEW (2010/30/EC) :	137
Freezer Net capacity (l) - NEW (2010/30/EC) :	0
Frost free system :	No
Freezing capacity (kg/24h) - NEW (2010/30/EC) :	0
Approval certificates :	G-Mark
:	White
Door panel options :	Possible but accessory
:	38
Energy Star Qualified :	No
Plug type :	Gardy plug w/ earthing
Required cutout/niche size for installation (in) :	x x
Dimensions of the packed product (in) :	35.03 x 26.37 x 24.40
Net weight (lbs) :	75.000
Gross weight (lbs) :	82.000



4 242002 755892

Serie | 2, built-under fridge, 82 x 60 cm KUR15A50NE

Performance and consumption

- Energy Efficiency Class: A+
- Energy consumption: 119 kWh/yr
- Gross capacity 139 l
- Net capacity: 137 l

Comfort and Safety

- Automatic defrost in fridge section
- Mechanical control

Fridge Section

- Net fridge capacity total: 137 l
- Gross capacity cooling 139 l
- 3 safety glass shelves of which 2 are height adjustable
- Interior with metal applications
- 1 x egg tray
- Door right hinged, reversible
- Climate Class: SN-T
- Dimensions (H x W x D): 82.0 cm x 59.8 cm x 54.8 cm

General Information

- Nominal voltage: 220 - 240 V

Serie | 2, built-under fridge, 82 x 60 cm
KUR15A50NE

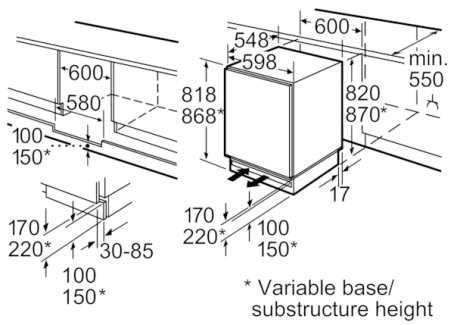

Space for electrical connection next to the appliance on the left or right-hand side.
 Ventilation space in the base.

Measurements in mm