

Serie | 6, built-under freezer, 82 x 59.8 cm
GUD15A50



Included accessories

2 x cold accumulator
 1 x ice cube tray

- Warning signal with sound or light when the door is not closed or other error happens.
- In case of power failure, the cooler plate is released by the accumulator to release the cool air to keep the tank temperature
- **SuperFreezing:** Protects frozen food from defrosting.

Technical data

Frost free system :	No
Climate class :	SN-ST
Door panel options :	Possible but accessory
:	598
:	548
Dimensions of the packed product (HxWxD) (mm) :	890 x 610 x 670
Warning signal / malfunction :	visual and audible
Defrost process :	manual
Cover door installation system :	Fixed-mounted
Number of drawers/baskets (Stck) :	3
Number of freezing flaps (Stck) :	0
Lockable door :	No
Thermometer freeze section :	Analog
Light :	No
Length electrical supply cord (cm) :	230
:	Right reversible
Net weight (kg) :	35.551
Gross weight (kg) :	38.5
Multi-Flow Air Tower :	No
Number of compressors :	1
Number of independent cooling systems :	1
Economy setting :	No
Fast freezing switch :	No
Door bin adjustability - Freezer :	No
Tilt-out door bins in freezer :	No
Door bin adjustability - Freezer :	No
Reversible Door Hinge :	Yes
:	90
Current (A) :	10
Frequency (Hz) :	50
Approval certificates :	CE, VDE
:	N/A
Door panel options :	Possible but accessory
:	38
Energy Star Qualified :	No
Approval certificates :	CE, VDE
Plug type :	Gardy plug w/ earthing
Required cutout/niche size for installation (in) :	x x
Dimensions of the packed product (in) :	35.03 x 26.37 x 24.01
Net weight (lbs) :	78.000
Gross weight (lbs) :	85.000



Serie | 6, built-under freezer, 82 x 59.8 cm GUD15A50

Performance and consumption

- Energy Efficiency Class: A+
- Energy consumption: 184 kWh/yr
- Net capacity: 98 l
- Noise level: 38 dB(A) re 1 pW

Design

- Combined to Fridge/Freezer combination

Comfort and Safety

- Flat hinge
- Mechanical control
- 1 compressor/1 cold circuit
- Visual and acoustic warning system in case of malfunction of the freezer compartment
- Super freezing with automatic switch off

Freezer Section

- Net capacity **** freezer: 98 l
- Freezing capacity: 12 kg/24 h
- Storage time in power failure: 23 h
- 3 transparent freezer drawers
- Calendar frozen food

Dimensions

- Dimensions (H x W x D): 82.0 cm x 59.8 cm x 54.8 cm
- Niche Dimension (H x W x D): 82.0 cm x 60.0 cm x 55.0 cm

Technical Information

- Door right hinged, reversible
- Connected load: 90 W
- Nominal voltage: 220 - 240 V
- Climate Class: SN-ST

Accessories

- cold accumulator, ice cube tray

Country Specific Options

- Gross capacity 114 l
- Gross capacity cooling 0 l
- Based on the results of the standard 24-hour test. Actual consumption depends on usage/position of the appliance.

Environment and Safety

Installation

**Serie | 6, built-under freezer, 82 x 59.8 cm
GUD15A50**

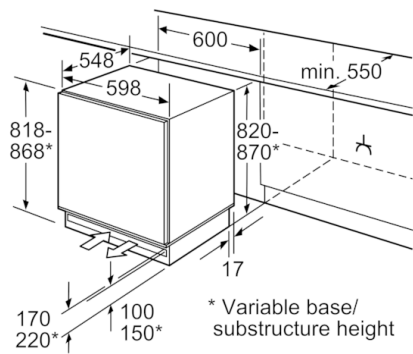

Space for electrical connection next to the appliance on the left or right-hand side.
Ventilation space in the base.

measurements in mm