

**Series 8, Built-in oven, 60 x 60 cm,
Black
HBG7341B1B**



2 x combination grid, 1 x universal pan

HEZ638000 Full ext rails, level independent, HEZ660060 Strip, HEZ664000 Baking and roasting grid (steam), HEZ915003 Glass roasting dish, 5,4 L, HEZ327000 Pizza stone, HEZ32WA00 Wireless food thermometer, HEZ530000 Half tray, HEZ531010 Baking tray, non-stick ceramic coated, HEZ532010 Universal pan, non-stick ceramic coated, HEZ538000 1fold telescopic rail, level independent, HEZ617000 Pizza pan, enamelled, HEZ629070 Air Fry & Grill tray, HEZ631070 Baking tray, enamelled, HEZ632070 Multipurpose pan, enamelled, HEZ633001 Lid for professional pan, enamelled, HEZ633070 Professional pan, enamelled, HEZ633073 Professional pan, enamelled, HEZ634000 Baking and roasting grid (standard), HEZ636000 Glass pan

The built-in oven with Digital Control Ring and TFT-touchdisplay. Assist function for meals, Air Fry, Home Connect for control via the App.

- **Eco Clean Direct:** less cleaning effort thanks to a special coating of the rear wall that automatically absorbs grime.
- **Flap door with Soft Open and Soft Close:** the oven door opens and closes gently and quietly.
- **Assist Function:** sets the optimal type of heat, temperature and time for a wide range of dishes.
- **Cooking tips:** Access practical cooking advice via the Home Connect app.
- **Dampened Hinges Softly and Quietly Guide the QuietClose® Door Shut.**

Gross weight: 37.2 kg
 Built-in / Free-standing: Built-in
 Integrated Cleaning system: EcoClean Direct program, Hydrolytic
 Min. required niche size for installation (HxWxD): 585-595 x 560-568 x 550 mm
 Dimensions: 595 x 594 x 548 mm
 Dimensions of the packed product (HxWxD): 670 x 670 x 680 mm
 Control Panel Material: Glass
 Door Material: Glass
 Net weight: 34.8 kg
 Usable volume of cavity: 71 l
 Heating modes: ... Defrost, Air fry, Full width grill, Hotair gentle, Hot Air, Half width grill, Conventional heat, Conventional heat gentle, Pizza setting, low temperature cooking, Bottom heat, Hot air grilling, pre-heating, warming
 Number of interior lights: 1
 Length electrical supply cord: 120.0 cm
 Interior Lights - cavity 1: 1
 Pull-out system: Accessory
 Included accessories: 2 x combination grid, 1 x universal pan
 Broil Element Wattages cavity 1: 2800 W
 Convection Element Wattages cavity 1: 2200 W
 Energy efficiency class: A+
 Energy consumption per cycle conventional (2010/30/EC): 0.87 kWh/cycle
 Energy consumption per cycle forced air convection (2010/30/EC): 0.69 kWh/cycle
 Energy efficiency index (2010/30/EC): 81.2 %
 Connection rating: 3600 W
 Fuse protection: 16 A
 Voltage: 220-240 V
 Frequency: 50; 60 Hz
 Plug type: No plug (electrical connection by electrician)
 Energy input: Electric
 Required cutout/niche size for installation (in): x
 Dimensions of the packed product: 26.37 x 26.37 x 26.77
 Net weight: 77.000 lbs
 Gross weight: 82.000 lbs
 Length electrical supply cord: 120.0 cm
 Net weight: 34.8 kg



Series 8, Built-in oven, 60 x 60 cm, Black HBG7341B1B

The built-in oven with Digital Control Ring and TFT-touchdisplay. Assist function for meals, Air Fry, Home Connect for control via the App.

Type of oven / heating system:

- Oven with 14 heating methods: Hot Air, Conventional heat, Hot air grilling, Full width grill, Half width grill, Pizza setting, Bottom heat, low temperature cooking, Defrost, pre-heating, Warming, Hotair gentle, Conventional heat gentle, Air fry
- Temperature range 30 °C °C - 300 °C °C
- Cavity volume: 71 l l

Hook-in racks / rails

- Number of shelf levels: 5 PC PC
- 1 level telescopic shelf, full extension, pyrolytic proof, with Stop function

Design

- Control Ring
- Digital Control Ring
- Cavity inner surface: Enamel anthracite

Cleaning:

- EcoClean Direct : Coating of back panel
- EcoClean Direct program
- Full glass inner door

Comfort

- Oven Assistant with Voice Control
- 2,5"-TFT-color and text display with touch-control buttons
- Electronic clock
- Temperature proposal, Actual temperature display, Heating-up control
- Oven door with SoftOpen and SoftClose, Drop down door
- soft opening
- Supporting systems: Programs
- Air Fry Function
- Rapid heating-up
- Halogen interior lighting
- Integral cooling fan
- Tính năng HomeConnect sử dụng wifi

Accessory

- combination grid, universal pan

Environment and Safety:

- low door temperature
- 3 PC glazed CoolTouch door
- Child lock Automatic switch off Residual heat indicator Start-/Stop button Door contact switch

Technical Information

- Length of mains cable: 120 cm
- Nominal voltage: 220 - 240 V
- Total connected load electric: Total connected load electric: 3.6

KW KW

- Energy efficiency rating (acc. EU Nr. 65/2014): A+(at a range of energy efficiency classes from A+++ to D)
- Energy consumption per cycle in conventional mode:0.87 kWh
- Energy consumption per cycle in fan-forced convection mode:0.69 kWh
- Number of cavities: 1 Heat source: electrical Cavity volume:71 l

Dimensions:

- Appliance dimension (hxwxh): 595 mm x 594 mm x 548 mm
- Niche dimension (hxwxh): 575 mm-597 mmx560 mm-568 mmx550 mm
- "Please reference the built-in dimensions provided in the installation drawing"

**Series 8, Built-in oven, 60 x 60 cm,
Black
HBG7341B1B**

Installing two appliances on top of each other
other
Air exchange

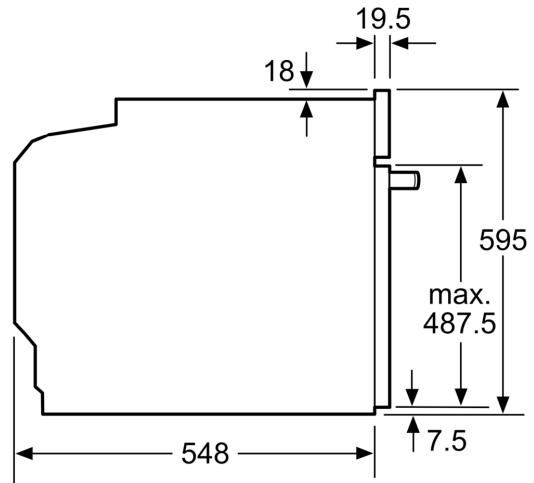
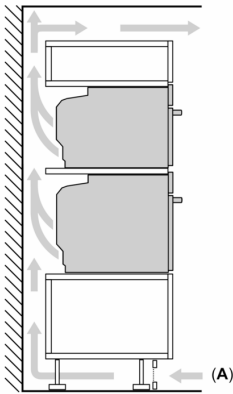

A: Air inlet $\geq 200 \text{ cm}^2$

measurements in mm

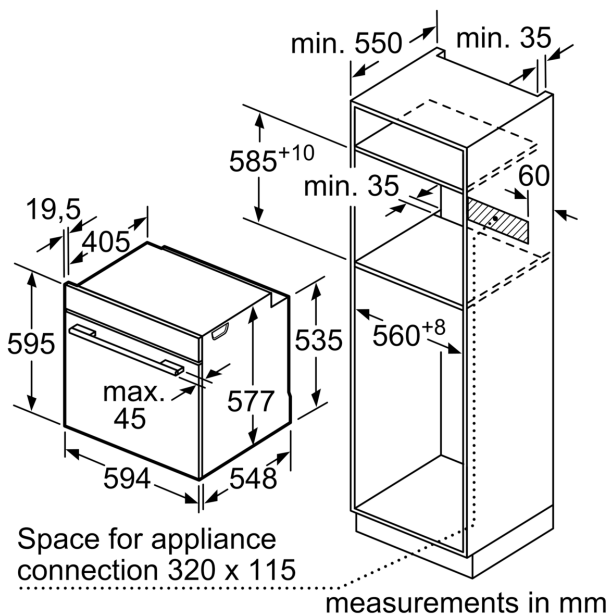

If the appliance will be installed underneath a hob, the following worktop thicknesses (including substructure if necessary) must be taken into account.

Hob type	min. worktop thickness	
	fitted	flush
Induction hob	37 mm	38 mm
Full surface Induction hob	47 mm	48 mm
Gas hob	30 mm	38 mm
Electric hob	27 mm	30 mm

