

Series 4, Built-In Microwave BFL523MS0B



Included accessories

1 x Turntable

- **Microwave:** time saving preparation, defrosting and re-heating of dishes.
- **AutoPilot 7:** every dish is a perfect success thanks to 7 pre-set automatic programmes.
- **LED-display control, red:** easy-to-use thanks to the time functions.
- **Pop-out controls:** for an easy to clean front.
- **Stainless steel interior:** easy to clean interior thanks to smooth surfaces and no sharp edges.

Technical Data

Type of control : Electronic

Color / Material Front : Stainless steel

Dimensions : 382 x 594 x 317 mm

Cavity dimensions : 201.0 x 308.0 x 282.0 mm

Length electrical supply cord : 130.0 cm

Net weight : 15.3 kg

Gross weight : 17.6 kg

Max. microwave power level : 800 W

Number of Power Levels : 5

Turntable : Yes

Cavity material : Stainless steel

Door opening : Button

Clock : Yes

Included accessories : 1 x Turntable

Main colour of product : Stainless steel

Height of the appliance : 382 mm

Width of the appliance : 594 mm

Depth of the product : 317 mm

Max. microwave power level : 800 W

Connection Rating : 1270 W

Fuse protection : 10 A

Voltage : 230-240 V

Plug type : GB plug

Color / Material Front : Stainless steel

Required cutout/niche size for installation (in) : x

Dimensions of the packed product : 17.32 x 14.96 x 25.98

Net weight : 34.000 lbs

Gross weight : 39.000 lbs

Included accessories : 1 x Turntable



Series 4, Built-In Microwave BFL523MS0B

Microwave and heating mode:

- Max. Power: 800 W; 5 Microwave power settings: 90 W, 180 W, 360 W, 600 W, 800 W
- Cavity volume: 20 l

Design

- LED display control
- Rotary Control, Pop-out controls, Touch control
- Stainless steel cavity

Comfort

- Electronic clock
- User-friendly electronics: extremely easy and comfortable operation
- AutoPilot 7
- 4 defrost and 3 cooking programmes in microwave function
- Memory for individual programmes (1 setting)
- LED light
- 25.5 cm glass turntable
- side opening door, hinge left
- Electronic door opener
- Touch key operation
- Automatic switch off Door contact switch
- Integral cooling fan
- Turntable

Technical Information

- Appliance dimension (hxwx): 382 mm x 594 mm x 317 mm
- Niche dimension (hxwx): 362 mm - 365 mm x 560 mm - 568 mm x 300 mm
- Suitable for high cupboard installation, Can be built in a 60 cm wall cupboard (at least 30cm deep)
- Length of mains cable: 130 cm
- Total connected load electric: 1.27 KW
- Nominal voltage: 230 - 240 V
- "Please reference the built-in dimensions provided in the installation drawing"
- The built-in microwave for the 38 cm niche: use it for thawing, heating and faster preparation of foods.

Series 4, Built-In Microwave BFL523MS0B

Microwave,
corner installation

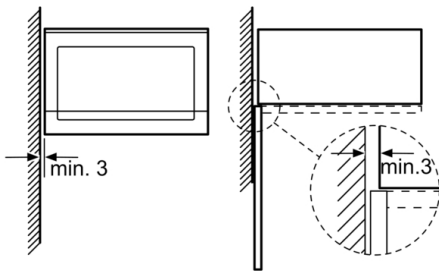

Measurements in mm

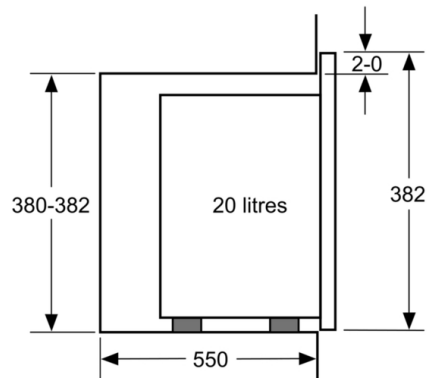

measurements in mm

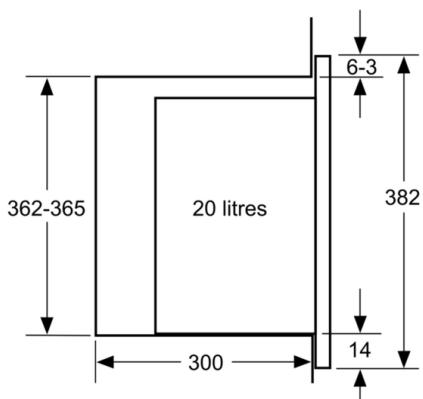

measurements in mm

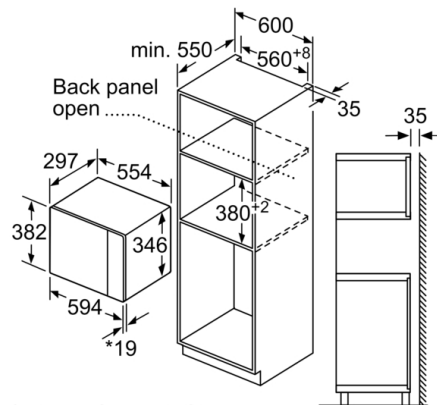

* 20 mm for metal fascia
measurements in mm

measurements in mm

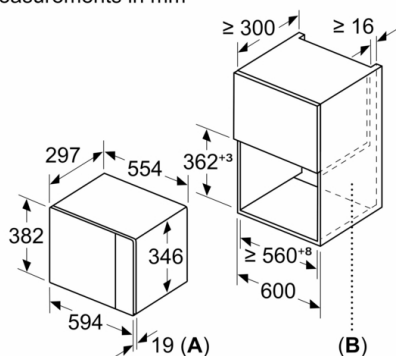

A: 20 mm for metal fascia
B: Back panel open