

**Blower
VTI2FZ**

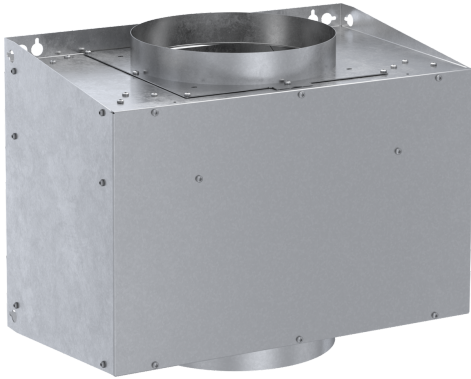

**1000 CFM inline blower can be mounted
along the duct line anywhere between the
kitchen and the exterior wall**

- EXTNCB25W 25-ft blower connector cable available, sold separately
- Mounted along the duct line between the kitchen and the exterior wall

Product group:Accessory
Brand:Thermador
Product name / series name:
SKU:VTI2FZ
Internal article number:VTI2FZ
EAN code:825225964865
Product Packaging Dimensions (HxWxD):18" x 24" x 27"
Net Weight:31.000 lbs
Gross Weight:34.000 lbs
Quantity per packing unit:
Standard number of units per pallet:
UPC code:825225964865
Product image:19805469_VTI2FZ_Front_Facing_3000_x_3000_def.jpg

EXTNCB25W 25 ft. Remote & Inline Blower Extension



**Blower
VTI2FZ**

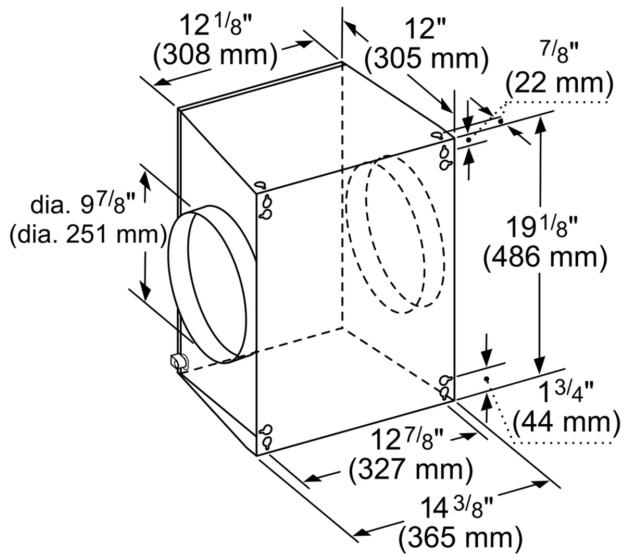

measurements in inches (mm)