

36-Inch Pro Harmony® Standard Depth Dual Fuel Range



Product Features

Innovation

The perfect blend of professional grade cooking with a New Contemporary Design that will fit seamlessly into any Kitchen style with a color TFT interface for a full range of cooking functions

Exclusive, patented Star® Burner – most even heating, unsurpassed flame coverage

Convection Bake offers precise multi-level baking results

Precision simmering capabilities as low as 100°F (375 BTU) with 2 ExtraLow® Simmer burners

Superfast 2-hour self-clean mode - fastest in the industry

Performance

ExtraLow® feature provides a wide range of temperature control, perfect for simmering delicate sauces

Electronic re-ignition will automatically re-ignite the burner in case the flame goes out

Every front burner provides 18,000 BTUs for added convenience

Three Full Access® telescopic rack holds up to 45 pounds, integrated easy grip handle

Powerful, 2,750 watt convection bake and 4,000 watt broil elements

Design

Truly Flush Mounted™, 24" standard cabinet depth

Patented Pedestal Star® Burner with QuickClean Base™

Powerful halogen lighting illuminates the oven cavity

Restaurant style metal knobs

Large oven door window for maximum viewing

Notes: Please refer to installation instructions. Installation instructions are available at www.thermador.com. Specifications are correct at the time of printing. Thermador reserves the right to change product specifications and design at any time, without notice.

1 800 735 4328 | WWW.THERMADOR.COM | 1901 Main Street, Suite 600 Irvine, CA 92614

©2022 BSH HOME APPLIANCES CORPORATION, ALL RIGHTS RESERVED LITHO DATE: 08/2022

36-Inch Pro Harmony® Standard Depth Dual Fuel Range

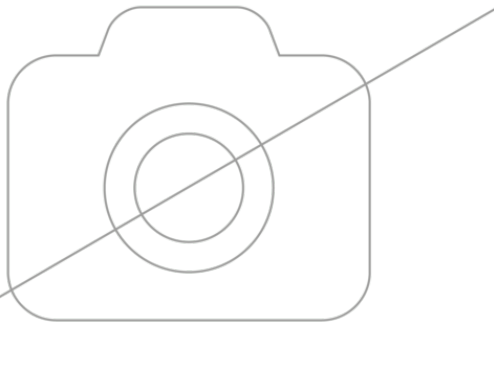
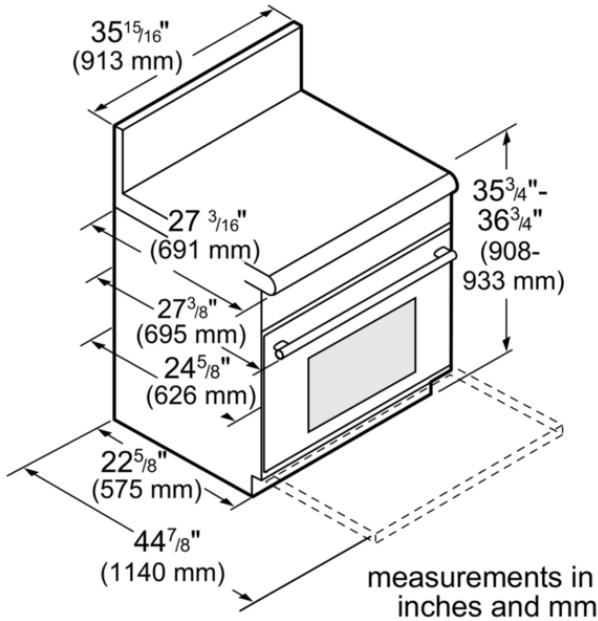

Product Features

Total number of cooktop burners	6
Cooking mode	3rd element convection, Centre-area grill/ broiler, Convection Bake, Convection Broil, Conventional heat, Roasting function, Selfcleaning pyrolytic
Integrated Cleaning system	Self Clean
Oven Control	Electronic
Knob Material	Full metal
Included accessories	1 x Broiler pan, 1 x island trim
Sealed Burners	Yes
Number of Double grates	3
Bake Element Wattages primary cavity	2000
Convection Element Wattages primary cavity	2750
Number of gas burners	6
Location of 1st heating element	front left
Power of 1st burner	18000
Location of 2nd heating element	center left
Location of 3rd heating element	back left
Power of 3rd burner (BTU)	15000
Location of 4th heating element	middle back
Power of 4th burner (BTU)	15000
Location of 5th heating element	back right
Power of 5th burner	15000
Location of 6th heating element	center right
Safety device	automatic reignition, Electronic flame control, Overheating protection, Thermostat

Technical Specification

UPC code	825225925194
Alternative gas type	Liquid gas 27,5 mbar (USA)
Total BTU load	99000
Watts	6400
Fuse protection	30
Volts	240/208
Frequency	60
Approval certificates	CSA
Overall appliance dimensions (HxWxD) (in)	36" width slide-in 35 7/8" x 35 15/16" x 24 3/4"
Variable cooker height (in)	1"
AHAM usable cavity size	3
Product packaging dimensions (HxWxD) (in)	49 1/4" x 43 1/2" x 40 3/8"
Gross weight	410
	417.000

Notes: Please refer to installation instructions. Installation instructions are available at www.thermador.com. Thermador reserves the right to change product specifications and design at any time, without notice.

1 800 735 4328 | WWW.THERMADOR.COM | 1901 Main Street, Suite 600 Irvine, CA 92614

©2022 BSH HOME APPLIANCES CORPORATION, ALL RIGHTS RESERVED LITHO DATE: 08/2022