

**Series 2, electric hob, 60 cm, Black,
PKE645CA2E**

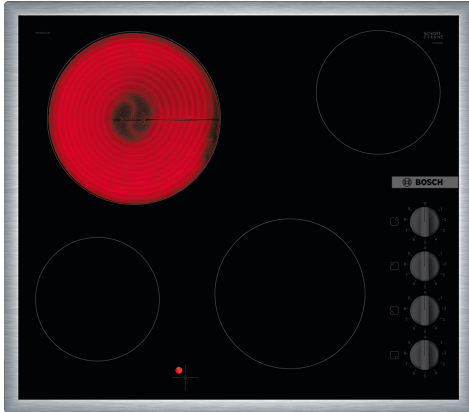

- HEZ32WA00 Wireless food thermometer
- HEZ390090 Wok Set consisting of 3 Items
- HEZ9SE030 Set of 2 pots and 1 pan

Product name/family: Cooking zone ceramic
 Built-in / Free-standing: Built-in
 Energy input: Electric
 Total number of positions that can be used at the same time: 4
 Min. required niche size for installation (HxWxD):48 x 560-560 x 490-500 mm
 Width of the appliance: 583 mm
 Dimensions: 48 x 583 x 513 mm
 Dimensions of the packed product (HxWxD): 96 x 755 x 590 mm
 Net weight: 7.4 kg
 Gross weight: 8.2 kg
 Residual heat indicator: Separate
 Location of control panel: Lateral
 Basic surface material: Ceramic
 Color of surface: Black, Stainless steel
 Color of frame: Stainless steel
 Knob Material: Plastic
 Sealed Burners: No
 Power of heating element (kW): 1.2 kW
 Power of 3rd heating element (kW): 2.2 kW
 Power of 5th heating element (kW): 1.2 kW
 Connection Rating: 6600 W
 Voltage: 220-240 V
 Frequency: 50; 60 Hz
 Energy input: Electric
 Plug type: no plug
 Appliance Dimensions (h x w x d) (in): x x
 Dimensions of the packed product: 3.77 x 23.22 x 29.72
 Net weight: 16.000 lbs
 Gross weight: 18.000 lbs
 Total number of positions that can be used at the same time: 4
 Min. required niche size for installation (HxWxD):48 x 560-560 x 490-500 mm
 Dimensions: 48 x 583 x 513 mm
 Dimensions of the packed product (HxWxD): 96 x 755 x 590 mm
 Net weight: 7.4 kg
 Gross weight: 8.2 kg



**Series 2, electric hob, 60 cm, Black,
PKE645CA2E**

**Series 2, electric hob, 60 cm, Black,
PKE645CA2E**

measurements in mm

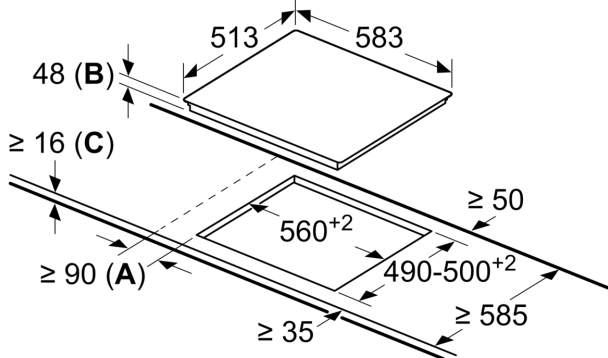

- A:** Minimum distance from the hob cut-out to the wall.
- B:** Recessed depth
- C:** With fitted oven underneath min. 20, possibly more; see space requirements for the oven.