

Series 6, Washing machine, front loader, 10 kg, , White WGG254A0SG



- WMZ2200 Floor securing component
- WMZ2381 Extension for cold water inlet /Aquastop
- WMZPW20W Platform with pull-out, washer, cubic

The smarter way to cleaner laundry is 100% accurate detergent-dosing everytime

- **i-DOS:** automatically measures the precise amount of detergent and water needed.
- **Eco Silence Drive™:** the efficient and highly durable washing machine drive.
- **Speed Perfect:** perfectly clean in up to 65% less time.
- **Allergy Plus:** developed for allergy sufferers and people with sensitive skin.
- **Vario Drum:** gently and efficiently wash with even water distribution and without creasing garments.

Built-in / Free-standing:Free-standing
 Door hinge:Left
 Color / Material body:White
 Length electrical supply cord:210.0 cm
 Height of the appliance:848 mm
 Dimensions of the product:848x598x590 mm
 Wheels:No
 Net weight:81.3 kg
 Drum volume:70 l
 Door Frame:Chrome, blackgray
 Color Dial:chrome
 Noise level washing:44 dB(A) re 1pW
 Connection rating:1900 W
 Fuse protection:10 A
 Voltage:220-240 V
 Frequency:50 Hz
 Energy Star Qualified:No
 Cord Included:Yes
 Plug type:GB plug
 Length of supply hose (in):59.05 "
 Dimensions of the packed product:35.03 x 26.57 x 27.95
 Net weight:179.000 lbs
 Gross weight:187.000 lbs
 Length of drain hose:150.00 cm
 Length of supply hose:150.00 cm
 Dimensions of the packed product (HxWxD):890 x 675 x 710 mm
 Gross weight:85.0 kg
 Connection rating:1900 W
 Fuse protection:10 A
 Voltage:220-240 V
 Frequency:50 Hz
 Water protection system:Multiple water protection
 Max. spin speed:1400 rpm
 Spin speed options:Variable
 Digital countdown indicator:Yes
 Drying progress indicator:LED-display
 Maximum capacity in kg (EU 2017/1369):10.0 kg



**Series 6, Washing machine, front loader, 10 kg, , White
WGG254A0SG**

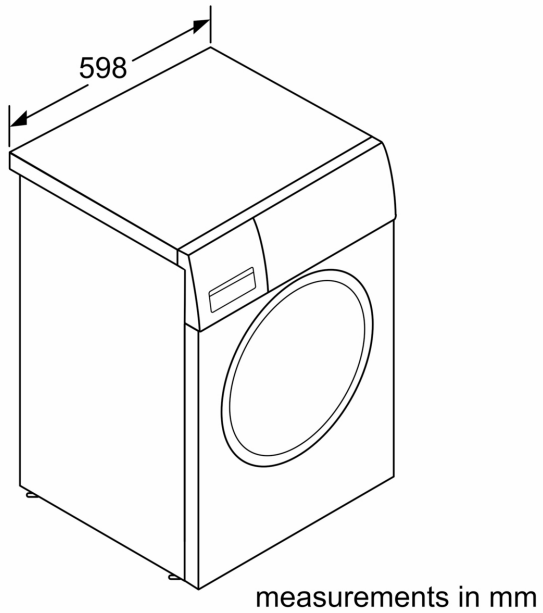

Measurements in mm

