

Series 4, Washing machine, front loader, 10 kg, 1400 rpm WGA25400SG



WMZ2381 Extension for cold water inlet /Aquastop

Stain expert washing machine with innovative Presoaking and AntiStain system: Automatic removal of stubborn stains even for delicate textiles with an extended capacity of 10 kg.

- **3 технологією Iron Steam Assist** складки на вашому одязі зменшуються до 50%.
- **The AntiStain option easily removes the up to 4 of the most stubborn stains, ranging from oil, tea, cosmetics and blood helping you get the perfect washing results, easily.**
- **Speed Perfect:** perfectly clean in up to 65% less time.
- **Allergy Plus:** developed for allergy sufferers and people with sensitive skin.
- **Vario Drum:** gently and efficiently wash with even water distribution and without creasing garments.

Built-in / Free-standing:	Free-standing
Door hinge:	Left
Color / Material body:	White
Length electrical supply cord:	160 cm
Height of the appliance:	845 mm
Dimensions of the product:	845x598x588 mm
Wheels:	No
Net weight:	73.1 kg
Drum volume:	70 l
Door Frame:	Silver-inox, black-grey
Connection rating:	2300 W
Fuse protection:	10 A
Voltage:	220-240 V
Frequency:	50-60 Hz
Energy Star Qualified:	Yes
Cord Included:	Yes
Plug type:	GB plug
Length of supply hose (in):	59.05 "
Dimensions of the packed product:	34.25 x 25.59 x 26.77
Net weight:	161.000 lbs
Gross weight:	163.000 lbs
Dimensions of the packed product (HxWxD):	870x650x680 mm
Gross weight:	74.1 kg
Connection rating:	2300 W
Fuse protection:	10 A
Voltage:	220-240 V
Frequency:	50-60 Hz
Water protection system:	Multiple water protection
Max. spin speed:	1400 rpm
Spin speed options:	Variable
Digital countdown indicator:	Yes
Drying progress indicator:	LED-display, LED
Maximum capacity in kg (EU 2017/1369):	10.0 kg



Series 4, Washing machine, front loader, 10 kg, 1400 rpm WGA25400SG

Stain expert washing machine with innovative Presoaking and AntiStain system: Automatic removal of stubborn stains even for delicate textiles with an extended capacity of 10 kg.

- Metal door closing hook
- magnet with pull-open latch

Technical Information

- Dimensions (H x W x D): 84.5 cm x 59.8 cm x 58.8 cm
- slide-under

-
- Front Load Washing Machine, 9kg 1400 rpm
 - EcoSilence Drive™

Performance

- Capacity 10 kg
- Energy Efficiency Class: A+++
- Energy consumption 191 kWh per year, based on 220 standard washing cycles for cotton programmes at 60°C and 40°C at full and partial load, and the consumption of the low power modes. Actual energy consumption will depend on how the appliance is used.
- energy consumption of the standard 60 °C cotton programme 1.2 kWh at full load and 0.6 kWh at partial load and of the standard 40 °C cotton programme 0.6 kWh at partial load
- weighted power consumption off-mode / left-on mode: 0.1 W / 0.5 W
- Water consumption 12100 litres per year, based on 220 standard washing cycles for cotton programmes at 60°C and 40°C at full and partial load. Actual water consumption will depend on how the appliance is used.
- spin-drying efficiency class: B
- Maximum Spin Speed : 1400 rpm
- programme time of the standard 60 °C cotton programme 305 min at full load and 290 min at partial load and of the standard 40 °C cotton programme 290 min at partial load

Programmes

Additional Information

- VarioPerfect™
- Touch Control Buttons : Start / Reload, Reduced Ironing, TurboPerfect, Spin Speed

Convenience and Safety

- Reload function: Be flexible in adding laundry items even after start of the wash cycle.
- WaveDrum
- Multiple water protection with magnetic valve to minimise risk of leakage
- Fully Electronic Selection Dial for Wash and Special Programmes
- AntiVibration™ provides more stability and quietness to your wash with its acoustic design side wall
- 3D AquaSpa wash system with cascade for faster water penetration
- Continuous automatic load adjustment
- loading introduction
- Foam Detection System
- Automatic Load Stabilisation
- Overdosage indication
- Child Proof Lock
- Buzzer

**Series 4, Washing machine, front loader, 10 kg, 1400 rpm
WGA25400SG**

Measurements in mm

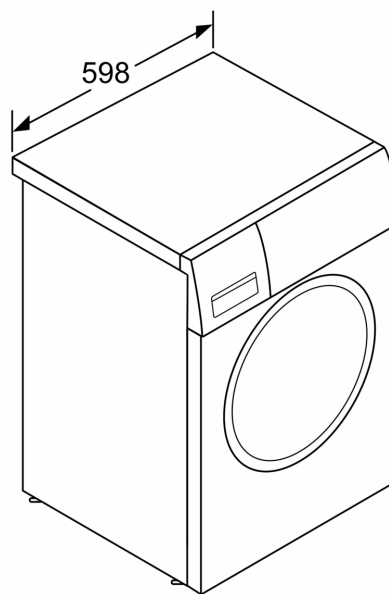
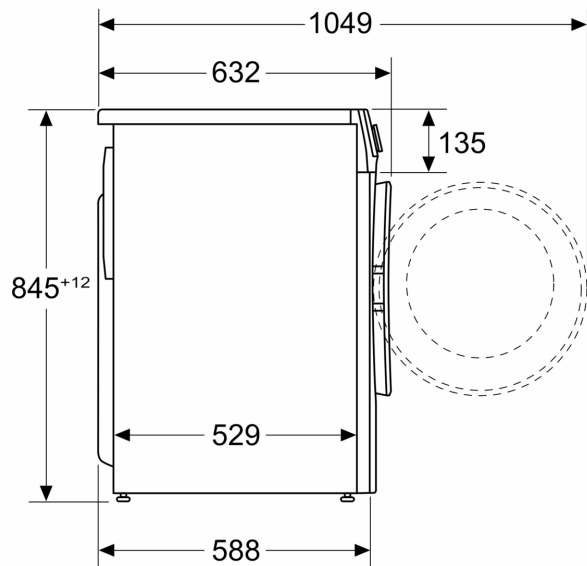

measurements in mm