

Series 2, Semi-integrated dishwasher, 45 cm, Stainless steel SPI2HKS59E



Connected dishwasher with noise reduction at any time via the Home Connect App.

- **Home Connect:** home appliances with smart connectivity for an easier everyday life.
- **7-Segment Display:** indicates remaining time and standard info, such as re-fill status.
- **EcoSilence Drive:** especially energy-saving and silent in operation with a particularly high life span.
- **Favourite function:** personalized function by just one touch even for downloaded programs.

- SGZ0BI02 decorative strips stainless steel 81,5cm
- SGZ1010 inlet and outlet hose extention
- SGZ3003 Silver polishing cassette
- SMZ1051EU Mains cable with EU-Plug 5m
- SMZ5000 Dishwashing aid set
- SMZ5003 Retractable hinge f. high corpus dimens.
- SMZ5300 GlassSecure Tray
- SPZ2044 Door and plinth panel, stainless steel

Energy Efficiency Class (Regulation (EU) 2017/1369): E
Energy Consumption for 100 cycles Eco Programme (EU 2017/1369):70 kWh
Maximum number of place settings (EU 2017/1369): 9
The water consumption of the eco programme in liters per cycle (EU 2017/1369):8.5 l
Programme duration (EU 2017/1369): 3:40 h
Airborne acoustical noise emissions (EU 2017/1369):	..46 dB(A) re 1 pW
Airborne acoustical noise emission class (EU 2017/1369): C
Cleaning performance:A
Water consumption:8.5 l
Total annual energy consumption 220 days: 170 kWh
Total annual water consumption 220 days: 1870 l
Built-in / Free-standing: Built-in
Removable top: No
Door panel options: Not possible
Height of removable worktop: 0 mm
Height of the appliance:815 mm
Adjustable feet: Yes - all from front
Maximum adjustability feet: 60 mm
Adjustable plinth: Both horizontal and vertical
Net weight:28.3 kg
Gross weight: 30.1 kg
Connection rating: 2400 W
Fuse protection:10 A
Voltage: 220-240 V
Frequency: 50; 60 Hz
Length electrical supply cord: 175.0 cm
Plug type: Gardy plug w/ earthing
Length inlet hose: 165 cm
Length outlet hose: 205 cm
Hidden heating element: Yes
Water protection system description: Triple water protection 24h
Child safety devices: Button suspension
Water softener:Yes
Top basket type: R2
Adjustable upper basket: Single
Bottom basket type: R2
3rd Rack: None
Optional accessories: ..SGZ0BI02, SGZ1010, SGZ3003, SMZ1051EU, SMZ5000, SMZ5003, SMZ5300, SPZ2044	
Included accessories 2:steam protection
Number of place settings:9
Color / Material panel: Stainless steel
Color / Material body: Lacquered
Dimensions of the product (HxWxD):815 x 448 x 573 mm
Dimensions of the packed product (HxWxD): 880 x 510 x 670 mm



Series 2, Semi-integrated dishwasher, 45 cm, Stainless steel SPI2HKS59E

Connected dishwasher with noise reduction at any time via the Home Connect App.

Specification

- Capacity: 9 place settings
- Dimension (WxHxD): 44.8 x 81.5 x 57.3 cm
- Noise level: 46 dB(A) re 1 pW
- Energy² / Water³: 70 kWh / 8.5 litres

Programmes

- 6 programmes: Eco 50 °C, Auto 45-65° 45-65 °C, Intensive 70 °C, Express 65° 65 °C, Silence 50 °C, Favourite
- 3 special options: Remote Start, Extra Dry, SpeedPerfect+

Features

- Noise level (silence programme): 43 dB(A) re 1 pW
- Wi-Fi
- Machine Care
- Silence on Demand (via app)
- Heat exchanger.
- Dosage Assist Basket ensures the tablets are dissolving properly
- BLDC Motor
- Favourite Programme
- Glass Care System
- Detergent Automation
- Time Delay: 1 - 24 hours
- Remaining programme time indicator (mins)
- 3-fold corrugated filter
- Inner Tub: Stainless Steel
- Funnel

Safety

- Aqua Stop - Prevent Water Leakage
- Childproof Control Lock

Baskets and Racks

- 2 bent spray arms in upper basket
- Low friction wheels on lower rack
- Rack Stopper to prevent derailing of lower basket
- Adjustable upper rack: Single
- 2 Foldable Plate Racks in Bottom Basket
- Cutlery rack in top basket
- Cutlery basket LR: variable small
- Incl. Steam Protection Plate

³ Water consumption in litres per cycle (in programme Eco 50 °C)

² Energy consumption in kWh per 100 cycles (in programme Eco 50 °C)

**Series 2, Semi-integrated
dishwasher, 45 cm, Stainless steel
SPI2HKS59E**

measurements in mm

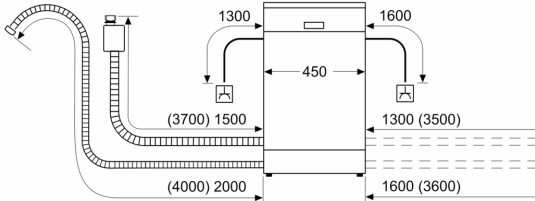

⌚ socket
() values with extension kit

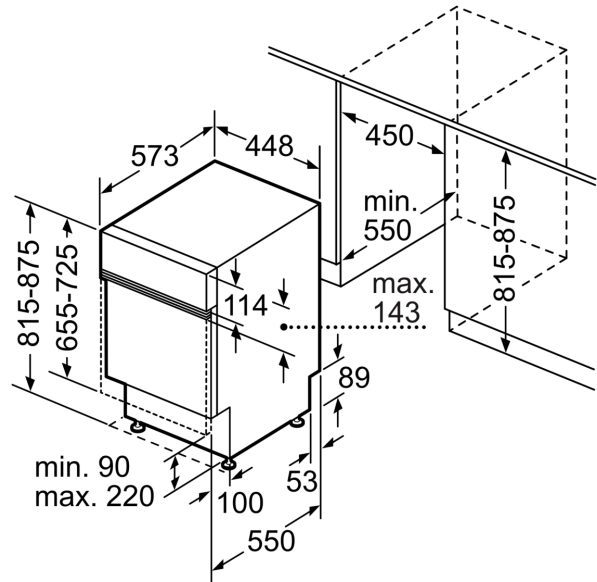

measurements in mm