

**Serie | 2, Built-in oven, Stainless steel  
HBN211E2K**

**Included accessories**

- 1 x alu baking tray
- 1 x combination grid
- 1 x universal pan

**The built-in oven with special hot air function: you achieve perfect baking and roasting results on up to two levels simultaneously.**

- **Hotair:** Perfect results thanks to optimal distribution of heat on up to 2 levels simultaneously.
- **Flap door:** for especially convenient opening and closing of the oven door.
- **Energy efficiency class A:** best baking results with low energy consumption.

**Technical Data**

Color / Material Front :	Stainless steel
Built-in / Free-standing :	Built-in
Integrated Cleaning system :	No
Required niche size for installation (HxWxD) :	575-597 x 560-568 x 550
Dimensions of the product (mm) :	595 x 595 x 548
Dimensions of the packed product (HxWxD) (mm) :	680 x 685 x 650
Control Panel Material :	Metal
Door Material :	Glass
Net weight (kg) :	32.482
Usable volume of cavity (l) :	66
Cooking method :	Circulating air, Conventional heat, Full width variable grill, Hot air grilling
First cavity material :	Enamelled
Number of interior lights :	1
Approval certificates :	CE, KEMA
Length electrical supply cord (cm) :	200
Interior Lights - cavity 1 :	1
Clock function :	Alarm
Included accessories :	1 x alu baking tray, 1 x combination grid, 1 x universal pan
Broil Element Wattages cavity 1 (W) :	2800
Energy efficiency class (2010/30/EC) :	A
Energy consumption per cycle conventional (2010/30/EC) :	0.96
Energy consumption per cycle forced air convection (2010/30/EC) :	0.88
Energy efficiency index (2010/30/EC) :	106.0
Connection Rating (W) :	2800
Current (A) :	13
Voltage (V) :	220-240
Frequency (Hz) :	50; 60
Plug type :	GB plug
Color / Material Front :	Stainless steel
Energy input :	Electric
Approval certificates :	CE, KEMA
Required cutout/niche size for installation (in) :	x x
Dimensions of the packed product (in) :	26.77 x 25.59 x 26.96
Net weight (lbs) :	72.000
Gross weight (lbs) :	76
Length electrical supply cord (cm) :	200
Net weight (kg) :	32.482
Gross weight (kg) :	35.0



## Serie | 2, Built-in oven, Stainless steel HBN211E2K

**The built-in oven with special hot air function: you achieve perfect baking and roasting results on up to two levels simultaneously.**

---

### **Performance**

- Oven with 4 heating modes:
  - Hot air grilling
  - Conventional heat
  - Circulating Air
  - Full width variable grill
- Cavity volume: 66 L
- Temperature range 50 °C - 270 °C

### **Features**

- Full glass inner door
- Heating up indicator
- Removable oven door for easy-cleaning

### **Design**

- Enamelled cavity
- mechanical timer
- Oven cavity with removable rack supports
- Interior lighting
- Glass inner door

### **Safety functions**

- Maximum window temperature 50° C
- Integral cooling fan

### **Technical information:**

- Dimensions of the product (HxWxD mm) : 595 x 595 x 548
- Electrical connection rating: 2,800 W

**Serie | 2, Built-in oven, Stainless steel  
HBN211E2K**

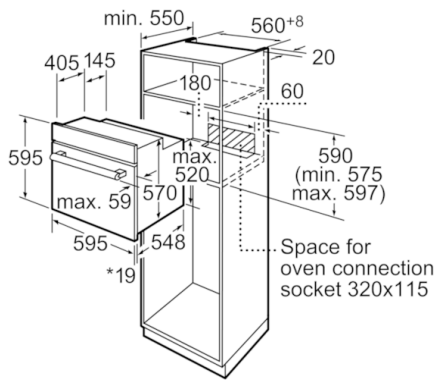

\*20 mm for metal fascias

Measurements in mm

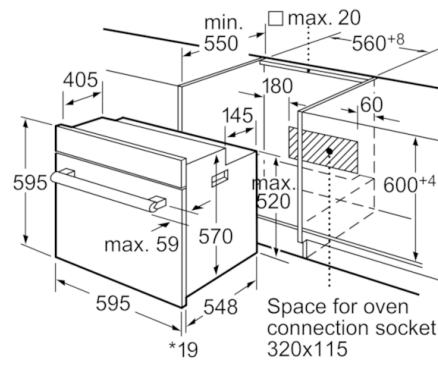

\*20 mm for metal fascias

Measurements in mm

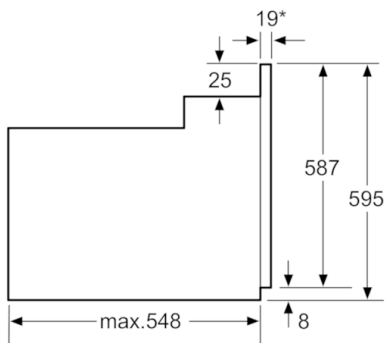

\* 20 mm for metal fascias

Dimensions in mm