

Series 4, Front Load Washing Machine, 10 kg, 1400 rpm WGA25400SG



WMZ2200 Floor securing component
 WMZ2381 Extension for cold water inlet /Aquastop

Stain expert washing machine with innovative Presoaking and AntiStain system: Automatic removal of stubborn stains even for delicate textiles with an extended capacity of 10 kg.

- Reduces wrinkles by up to 50%
- Speed Perfect: perfectly clean in up to 65% less time
- .
- EcoSilence Drive™: extremely energy-efficient and quiet in operation with an especially long life.
- Vario Drum: gently and efficiently wash with even water distribution and without creasing garments.
- Active Water Plus: For highly efficient use of water even with smaller loads thanks to automatic load detection.

Built-in / Free-standing:Free-standing
 Door hinge: Left
 Color / Material body: White
 Length electrical supply cord: 160.0 cm
 Height of the appliance: 845 mm
 Dimensions of the product: 845 x 598 x 588 mm
 Wheels: No
 Net weight: 73.3 kg
 Drum volume: 70 l
 Door Frame: Silver-innox, black-grey
 Connection rating: 2300 W
 Fuse protection: 10 A
 Voltage: 220-240 V
 Frequency: 50-60 Hz
 Energy Star Qualified: Yes
 Cord Included: Yes
 Plug type: GB plug
 Length of supply hose (in): 59.05 "
 Dimensions of the packed product: 34.64 x 25.19 x 26.77
 Net weight: 162.000 lbs
 Gross weight: 163.000 lbs
 Length of drain hose: 150.00 cm
 Length of supply hose: 150.00 cm
 Dimensions of the packed product (HxWxD): 880 x 640 x 680 mm
 Gross weight: 74.1 kg
 Connection rating: 2300 W
 Fuse protection: 10 A
 Voltage: 220-240 V
 Frequency: 50-60 Hz
 Water protection system: Multiple water protection
 Max. spin speed: 1400 rpm
 Spin speed options: Variable
 Digital countdown indicator: Yes
 Progress indicator: LED-display, LED
 Capacity: 10.0 kg



Series 4, Front Load Washing Machine, 10 kg, 1400 rpm WGA25400SG

Stain expert washing machine with innovative PreSoaking and AntiStain system: Automatic removal of stubborn stains even for delicate textiles with an extended capacity of 10 kg.

- Front Load Washer

Performance

- Capacity 10 kg
- EcoSilence Drive
- BLDC with warranty
- Energy Efficiency Class: A+++
- Energy consumption 191 kWh per year, based on 220 standard washing cycles for cotton programmes at 60°C and 40°C at full and partial load, and the consumption of the low power modes. Actual energy consumption will depend on how the appliance is used.
- Energy consumption of the standard 60 °C cotton programme 1.2 kWh at full load and 0.6 kWh at partial load and of the standard 40 °C cotton programme 0.6 kWh at partial load.
- Weighted power consumption off-mode / left-on mode: 0.1 W / 0.5 W
- Water consumption 12100 litres per year, based on 220 standard washing cycles for cotton programmes at 60°C and 40°C at full and partial load. Actual water consumption will depend on how the appliance is used.
- Spin-drying efficiency class: B
- Maximum Spin Speed : 1400 rpm
- Programme time of the standard 60 °C cotton programme 305 min at full load and 290 min at partial load and of the standard 40 °C cotton programme 290 min at partial load.

Programmes

Options

- PreSoaking: Works against stubborn stains.
- AntiStain: Automatic removal of the most common stains.
- VarioPerfect: time - or energy optimized programs with perfect wash performance
- TouchControl buttons: Reduced Ironing, Ready in, Temperature, TurboPerfect, start/pause with reload function, stain selection, Rinse plus +1+2+3, Spin speed reduction/Rinse hold

Convenience and Safety

- Reload function: Be flexible in adding laundry items even after start of the wash cycle.
- WaveDrum
- Multiple water protection with magnetic valve to minimise risk of leakage
- Large display for programme progress indication, temperature, spin speed, remaining time, 24 h end time delay and load recommendation
- Large display for temperature, spin speed, remaining time, 24 h end time delay and load recommendation
- Fully electronic control dial for all wash- and special programs
- AntiVibration Design: more stability and quietness

- Continuous automatic load adjustment
- loading introduction
- Foam detection system to remove excessive foam
- Unbalanced load detection
- Self cleaning detergent drawer
- Overdosage indication
- Child Proof Lock
- Buzzer warning signal
- Metal door closing hook
- Magnet with pull-open latch

Technical information

- Dimensions (H x W x D): 84.5 cm x 59.8 cm x 58.8 cm
- Built-under option

**Series 4, Front Load Washing
Machine, 10 kg, 1400 rpm
WGA25400SG**

Measurements in mm

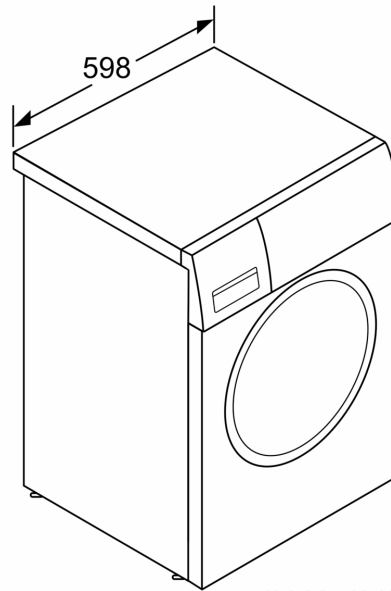
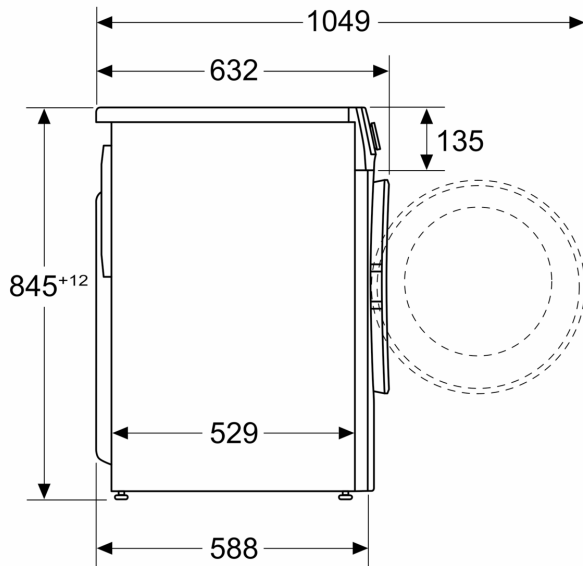

measurements in mm