

Series 4, Front Load Washing Machine, 9 kg, 1400 rpm WGA14400SG



- **Iron Steam Assist:** reduce wrinkles up to 50%
- .
- **The AntiStain option easily removes up to 4 of the most stubborn stains, ranging from oil, tea, cosmetics and blood helping you get the perfect washing results, easily.**
- **Reduces wrinkles by up to 50%**
- **The SpeedPerfect™ option washes in a shorter time with the cleaning results of the standard program.**
- **Eco Silence Drive™: the efficient and highly durable washing machine drive.**

Built-in / Free-standing: Free-standing
 Door hinge: Left
 Color / Material body: White
 Length electrical supply cord: 160.0 cm
 Height of the appliance: 845 mm
 Dimensions of the product: 845 x 597 x 588 mm
 Wheels: No
 Net weight: 71.0 kg
 Drum volume: 65 l
 Door Frame: Silver-inox, black-grey
 Noise level washing: 55 dB(A) re 1 pW
 Connection rating: 2300 W
 Fuse protection: 10 A
 Voltage: 220-240 V
 Frequency: 50 Hz
 Energy Star Qualified: No
 Cord Included: Yes
 Plug type: GB plug
 Length of supply hose (in): 59.05 "

Dimensions of the packed product: 34.64 x 25.19 x 26.77
 Net weight: 157.000 lbs
 Gross weight: 158.000 lbs
 Length of drain hose: 150.00 cm
 Length of supply hose: 150.00 cm
 Dimensions of the packed product (HxWxD): 880 x 640 x 680 mm
 Gross weight: 71.8 kg
 Connection rating: 2300 W
 Fuse protection: 10 A
 Voltage: 220-240 V
 Frequency: 50 Hz
 Energy consumption: 0.62 kWh
 Water consumption: 44.0 l
 Water protection system: Multiple water protection system
 Max. spin speed: 1400 rpm
 Spin speed options: Variable
 Digital countdown indicator: Yes
 Progress indicator: LED-display, LED
 Capacity: 9.0 kg

WMZ2200 Floor securing component
 WMZ2381 Extension for cold water inlet /Aquastop



**Series 4, Front Load Washing
Machine, 9 kg, 1400 rpm
WGA14400SG**

Measurements in mm

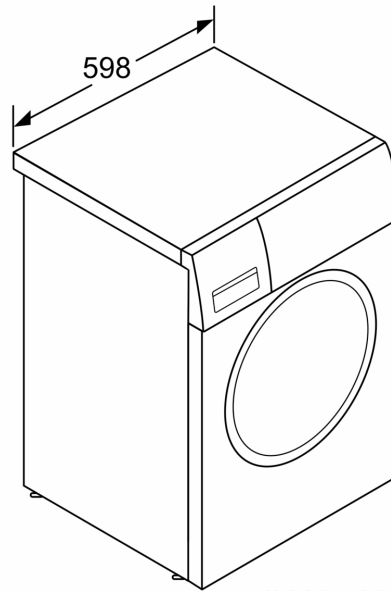
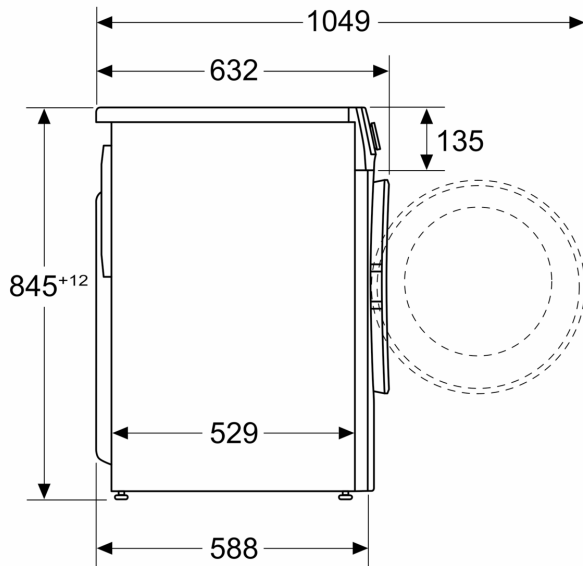

measurements in mm