

**Series 8, Induction Hob, 80 cm,
Black,
PXV890DV5E**



HEZ390230 System pan diameter 21cm, HEZ390512 Teppan Yaki (large), HEZ390522 Griddle Plate, HEZ394301 Connecting strip, HEZ9ES100 Espresso maker 4 cups, HEZ9FE280 Iron pan Ø 18 / 28 cm, HEZ9FF010 Flex Pan, large, HEZ9FF030 Flex Pan set, 3 pcs., HEZ9FF040 Flex Pan set, 4 pcs., HEZ9SE040 4 pieces Set, HEZ9SE060 6 pieces Set, HEZ9TY010 Teppan Yaki, HZ390011 Stainless Steel roaster with glass lid, HEZ32WA00 Wireless food thermometer, HEZ390012 Steaming Rack for Stainless Steel roaster, HEZ390090 Wok Set consisting of 3 Items, HEZ390210 System pan diameter 15 cm, HEZ390220 System pan diameter 19 cm

**The FlexInduction hob: you can place
multiple pots and pans or large cookware
anywhere on the flexible cooking zone.**

- **Cooktop with GlassProtect surface:** the new coating increases the scratch-resistance of the cooktop surface.
- **FlexInduction:** more flexibility on your hob for large pots and pans.
- **DirectSelect Premium:** spacious and intuitive touch interface.
- **PerfectFry:** no more worries about scorching.
- **Move Mode:** the automatic setting of cooking levels allows fast boiling on the front, cooking on the middle and simmering on the rear cooking zone.

Product name/family: Cooking zone ceramic
 Built-in / Free-standing: Built-in
 Energy input: Electric
 Total number of positions that can be used at the same time: 5
 Min. required niche size for installation (HxWxD): 51 x 750-780 x 490-500 mm
 Width of the appliance: 816 mm
 Dimensions (HxWxD): 51 x 816 x 527 mm
 Dimensions of the packed product (HxWxD): 130 x 950 x 600 mm
 Net weight: 14.2 kg
 Gross weight: 17.9 kg
 Residual heat indicator: Separate
 Location of control panel: Front
 Basic surface material: Ceramic
 Color of surface: Black
 Length electrical supply cord: 110.0 cm
 Sealed Burners: No
 Heating with booster: All
 Power of heating element (kW): 1.8 kW
 Power of 3rd heating element (kW): 1.4 kW
 Power of heating element (kW in boost): [3.1] kW
 Power of 3rd heating element (kW in boost): [2.2] kW
 Connection rating: 7400 W
 Voltage: 220-240 V
 Frequency: 50-60 Hz
 Energy input: Electric
 Plug type: no plug
 Appliance Dimensions (h x w x d) (in): x x
 Dimensions of the packed product: 5.11 x 23.62 x 37.40
 Net weight: 31.000 lbs
 Gross weight: 39.000 lbs
 Total number of positions that can be used at the same time: 5
 Length electrical supply cord: 110.0 cm
 Min. required niche size for installation (HxWxD): 51 x 750-780 x 490-500 mm
 Dimensions (HxWxD): 51 x 816 x 527 mm
 Dimensions of the packed product (HxWxD): 130 x 950 x 600 mm
 Net weight: 14.2 kg
 Gross weight: 17.9 kg



Series 8, Induction Hob, 80 cm, Black, PXV890DV5E

The FlexInduction hob: you can place multiple pots and pans or large cookware anywhere on the flexible cooking zone.

- 80 cm: space for 5 pots or pans.

Flexibility of cooking zones

- Flex zone: use cookware of any shape or size anywhere within the 40cm long zone.
- Cooking zone front left: 180 mm, 1.8 KW (max. power 3.1 KW)
- Cooking zone rear left: 145 mm, 1.4 KW (max. power 2.2 KW)
- Cooking zone rear middle: 240 mm, 2.2 KW (max. power 3.7 KW)
- Cooking zone rear right: 200 mm, 210 mm, 2.2 KW (max power 3.7 KW)
- Cooking zone front right: 200 mm, 210 mm, 2.2 KW (max. power 3.7 KW)

Features

- Direct Select 2.0: directly control the power on the extra large illuminated touch bar (invisible when switched off).
- 17 power levels: precisely adapt the heat with 17 power levels (9 main levels and 8 intermediate levels).
- Keep warm function: keep dishes warm at preset low power level.
- Switch off timer for every cooking zone: switches off the cooking zone at the end of the time set (e.g. for boiled eggs).
- Count-down timer: an alarm sounds at the end of the time set (e.g. for pasta).
- Count-up timer: shows how much time has passed since starting the timer (e.g. for potatoes).

Time saving & efficiency

- Boost function for all zones: boil water more quickly thanks to 50% more energy than at the highest standard level.
- All: heat up pans more quickly than at the highest standard level while protecting the pan coating.
- 3-steps: increase or decrease the power level simply by moving the pot forwards or backwards.
- yes: when switching on, the hob automatically selects the cooking zone with cookware (placed in off-mode).
- ReStart Function: in case of unintentional switch-off, restore all previous settings by switching on the hob again within 4 seconds.

Cooking assistance

- 5 frying levels: prevents scorching with the automatic temperature regulation of the integrated sensor.
- Dish assistant: easily find the right temperature setting for a certain dish via the home connect app.

Connectivity

- Remote Monitoring and Control: check if the hob is switched off even when not at home, and find recipes or additional functions in the Home Connect app.
- Hood (Wi-Fi): automatically activates the hood when cooking, thanks to the WiFi connection of hob and suitable hood.

Design

- Hightrans Eco Miradur: scratch-resistant glass ceramics.

Safety

- Digital 2 stage residual heat indicator: indicates which cooking zones are still hot or warm.
- Childproof lock: prevent unintended activation of the hob.
- Wipe protection function: wipe overboiled liquids without unintentionally changing settings (blocking all touch buttons for 30 seconds).
- Main switch: switch off all cooking zones at the touch of a button.
- Safety switch-off: for safety reasons, heating stops after a preset time without interaction.
- Energy consumption display: shows the electricity consumption of the last cooking process.

Installation

- Dimensions of the product (HxWxD mm): 51 x 816 x 527
- Required niche size for installation (HxWxD mm) : 51 x 750 x (490 - 500)
- Min. worktop thickness: 16 mm
- Connected load: 7.4 KW
- PowerManagement Function: limit the maximum power if needed (depends on fuse protection of electric installation).
- Power cord: 1.1 m, loose insert in packaging

**Series 8, Induction Hob, 80 cm,
Black,
PXV890DV5E**

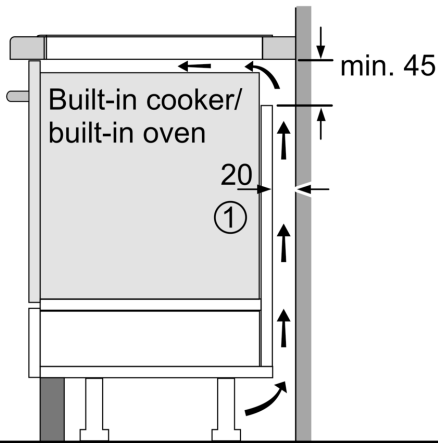

①
Ventilation gap must
be present

All measurements in mm

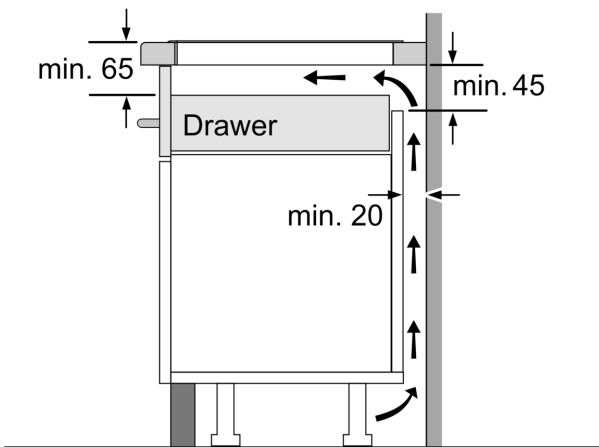

Measurements in mm

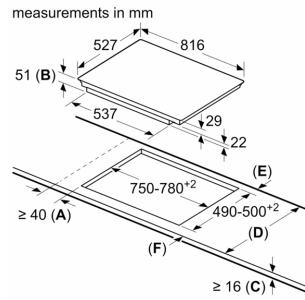

A: Minimum distance from the hob cut-out to the wall.
B: Recessed depth
C: The clearance between the surface of the worktop and the top of the front of the oven must be 30 mm. See space requirements for the oven.

The worktop into which the hob is installed must withstand loads of approx. 60 kg; suitable substructures must be used if required.

D	E	F
585-600	50	≥ 35
> 600	≥ 50	≥ 50

