

**Series 4, multi door French Door
Bottom Freezer, 183 x 90.5 cm,
Stainless steel (with anti-fingerprint)
KFN96APEAG**



- **Metal Backwall with Multi Airflow:** evenly circulates cool, fresh air to maintain consistent temperatures.
- **XXL capacity:** extra space for your food when you need it.
- **LED lighting:** keep your groceries in perfect view.
- **Big Box drawer:** for stacking storage containers or for large frozen food items.
- **VitaFresh XXL <0°C>:** keeps food fresh for longer in extra-large climate-controlled fridge drawers.

Energy label: E
Average annual energy consumption: 333 kWh/annum
Capacity frozen compartments: 200 l
Capacity chill compartments: 405 l
Noise level: 38 dB(A) re 1 pW
Noise level class: C
Built-in / Free-standing: Free-standing
Number of compressors: 1
Number of independent cooling systems: 1
Width of the appliance: 905 mm
Height: 1830 mm
Depth of the product: 731 mm
Net weight: 118.3 kg
Door panel options: Not possible
Door hinge: left and right
Number of Adjustable Shelves in fridge compartment: 3
Shelves for Bottles: No
Frost free system: Freezer
Interior ventilator: Yes
Reversible Door Hinge: No
Length electrical supply cord: 240.0 cm
Noise level: 38 dB(A) re 1 pW
Multi-Flow Air Tower: Yes
Fast cooling switch: Yes
Fast freezing switch: Yes
Temperature Controlled Drawer: No
Humidity Control Drawer: No
Number of door bins - Refrigerator: 4
Door bin adjustability - Refrigerator: Yes
Tilt-out door bins in fridge: Yes
Gallon Storage: Yes
Number of Gallon storage: 2
Motorized Shelf: No
Material of the shelves: Safety glass
Door opened indicator freezer: Yes
Automatic motor-driven ice-maker: No
Fuse protection: 10 A
Voltage: 220-240 V
Frequency: 50-60 Hz
Storage Period in Event of Power Failure (h): 15 h
Door panel options: Not possible
Noise level: 38 dB(A) re 1 pW
Energy Star Qualified: No
Plug type: GB plug
Required cutout/niche size for installation (in): X
Dimensions of the packed product: 74.99 x 39.29 x 30.70
Net weight: 261.000 lbs
Gross weight: 284.000 lbs



Series 4, multi door French Door Bottom Freezer, 183 x 90.5 cm, Stainless steel (with anti-fingerprint) KFN96APEAG

- NoFrost, Free-standing-refrigerator >= 3 door
- inox EasyClean Doors

General Data

- Total Volume : 605 l
- Net Fridge Volume : 405 l
- Net Freezer Volume : 200 l
- Freezing capacity 24h : 13 kg
- Annual Energy Consumption: 333 kWh/a
- Noise Level : 38 dB

Design and Styling

- Door inox EasyClean, side panels Metallic chrome
- Classic door , Door inox EasyClean, side panels Metallic chrome
- LED interior light in fridge section
- Metal backwall
- Interior with metal applications

Convenience & Safety

- 7 segment electronic control
- Supercool function
- Automatic defrost in fridge section
- acoustic for Fridge and Freeze, Optical warning system Door open
- Acoustic Warning System, Optical Warning System by Temperatur increase

Fridge Compartment

- Multi Airflow-System
- 4 safety glass shelves of which 3 are height adjustable
- 2door trays (large)
- 2 door trays (small)
- none/0
- Dairy compartment

Freshness System

- 1 Chiller
- 1veg.cont.w.int.hum.contr.o.ra

Freezer Compartment

- 6 transparent freezer drawers
- Ice cube tray
- Without Illumination in freezer section

Appliance Dimension

- Appliance Height: 1830 mm
- Appliance Width:905 mm
- Appliance Depth:731 mm

Technical Information

- 4 wheels for easier transport, 3 of them height adjustable.
- Acoustic Warning System
- Voltage 220 - 240 V
- Based on the results of the standard 24-hour test. Actual consumption depends on usage/position of the appliance.

**Series 4, multi door French Door
Bottom Freezer, 183 x 90.5 cm,
Stainless steel (with anti-fingerprint)
KFN96APEAG**

Measurements in mm

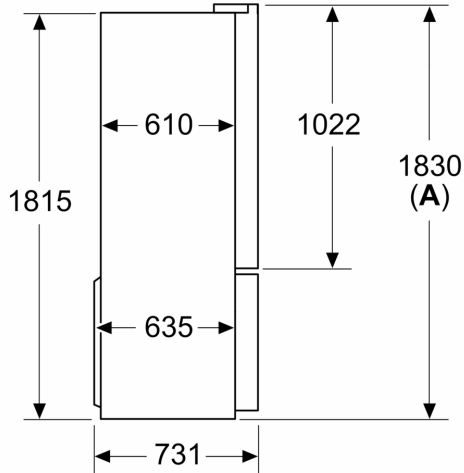

A: Front is adjustable 1830–1847 mm, with front levelling feet fully extended

Measurements in mm

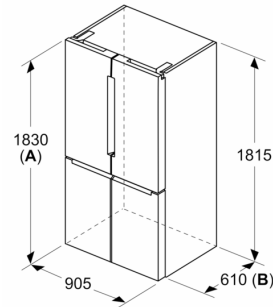

A: Front is adjustable 1830–1847 mm, with front levelling feet fully extended

B: Add 25 mm for fixed spacers on back

Measurements in mm

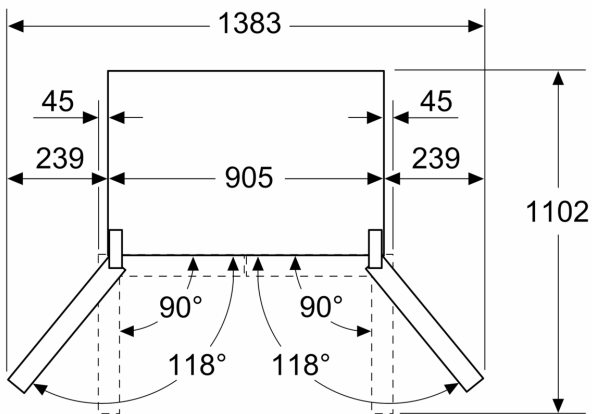

Measurements in mm

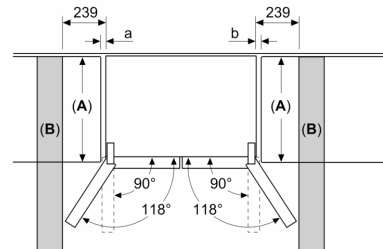

A	a	b
≤ 600	0	0
600 < A ≤ 650	45	45
650 < A ≤ 700	60	60
> 700	239	239

A: Kitchen cabinet or worktop depth

B: Wall
Drawers can be pulled and taken out with door open to 90°