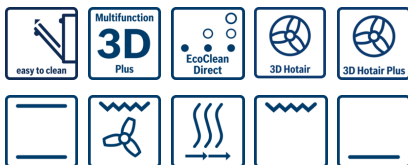

Serie | 6
66 | Oven

Included accessories

1 x enamel baking tray
1 x combination grid
1 x universal pan

The built-in oven with cleaning aid: you have to clean less thanks to reduced soiling during the cooking process.

- **EcoClean:** almost no cleaning is necessary thanks to a special coating that automatically absorbs grime.
- **3D Hotair Plus:** perfect results thanks to optimal distribution of heat on up to 3 levels simultaneously.
- **Energy efficiency class A:** Best baking results with low energy consumption

Technical Data

Color / Material Front :	Stainless steel
Built-in / Free-standing :	Built-in
Integrated Cleaning system :	No
Required niche size for installation (HxWxD) :	575-597 x 560-568 x 550
Dimensions of the product (mm) :	595 x 595 x 548
Dimensions of the packed product (HxWxD) (mm) :	670 x 680 x 670
Control Panel Material :	Stainless steel
Door Material :	Glass
Net weight (kg) :	34.698
Usable volume of cavity (l) :	66
Cooking method :	Bottom heat, Conventional heat, Full width variable grill, Hot Air, Hot air grilling
First cavity material :	Enamelled
Number of interior lights :	1
Approval certificates :	CE, VDE
Length electrical supply cord (cm) :	120
Interior Lights - cavity 1 :	1
Pull-out system :	Accessory
Clock function :	Alarm, Off, On
Included accessories cavity 1 :	1 x enamel baking tray, 1 x combination grid, 1 x universal pan
Broil Element Wattages cavity 1 (W) :	2800
Convection Element Wattages cavity 1 (W) :	1600
Energy efficiency class (2010/30/EC) :	A
Energy consumption per cycle conventional (2010/30/EC) :	0.96
Energy consumption per cycle forced air convection (2010/30/EC) :	0.82
Energy efficiency index (2010/30/EC) :	98.8
Electrical connection rating (W) :	2900
Current (A) :	13
Voltage (V) :	220-240
Frequency (Hz) :	50; 60
Plug type :	GB plug
Color / Material Front :	Stainless steel
Energy input :	Electric
Approval certificates :	CE, VDE
Required cutout/niche size for installation (in) :	x x
Dimensions of the packed product (in) :	26.37 x 26.37 x 26.77
Net weight (lbs) :	76.000
Gross weight (lbs) :	81
Length electrical supply cord (cm) :	120
Net weight (kg) :	34.698
Gross weight (kg) :	37.0



4 242002 845050

Serie | 6 Ovens

66 | Oven

The built-in oven with cleaning aid: you have to clean less thanks to reduced soiling during the cooking process.

-
- Multifunction oven (5 cooking functions: conventional heat, hot air plus, bottom heat, hot air grilling, full width variable grill)
 - Extra large capacity oven with grey enamel
 - rear panel with EcoClean, side and top as optional accessory
 - Accurate temperature control 50-270°C
 - Automatic rapid heating up
 - Childproof lock
 - Maximum window temperature 40°C
 - Retractable rotary knobs
 - Electronic clock with timer
 - Oven interior light
 - Triple glass door
 - Integral cooling fan
 - Telescopic shelf rails as optional accessory
 - 1 x enamel baking tray, 1 x combination grid, 1 x universal pan
 - Energy efficiency rating (acc. EU Nr. 65/2014): A (at a range of energy efficiency classes from A+++ to D)
Energy consumption per cycle in conventional mode: 0.96 kwh
Energy consumption per cycle in fan-forced convection mode: 0.82 kwh
Number of cavities: 1
Heat source: electrical
Cavity volume: 66 l

Serie | 6 Ovens

66 | Oven

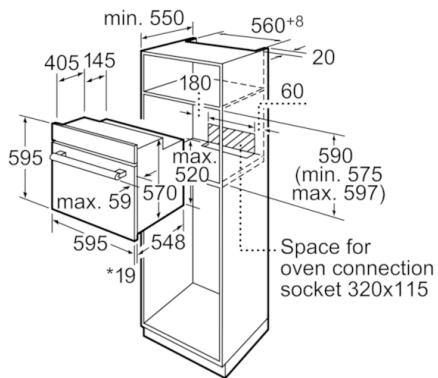

*20 mm for metal fascias

Measurements in mm

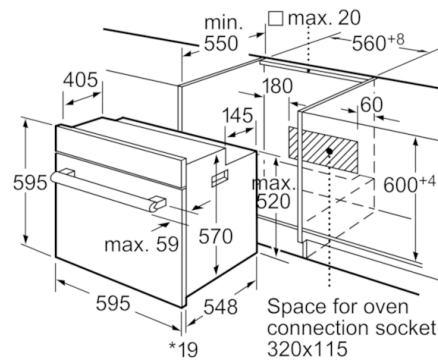

*20 mm for metal fascias

Measurements in mm

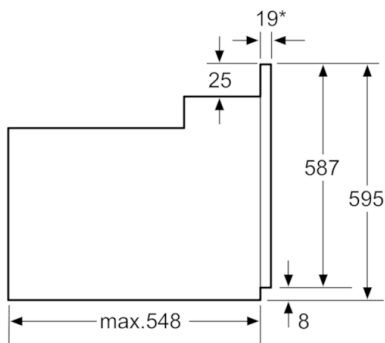

* 20 mm for metal fascias

Dimensions in mm