

## Series 8, heat pump dryer, 9 kg WQB246C9GB



**A+++**



- **AutoDry:** gently dries laundry to precisely the degree of dryness you want.
- **Self Cleaning Condenser:** keeps the condenser free of fluff to maintain optimal energy efficiency.
- **Smart Dry:** automatically selects the best drying program based on the last washing cycle.
- **Home Connect:** home appliances with smart connectivity for an easier everyday life.
- **Smart energy management for your tumble dryer.**

---

Built-in / Free-standing: ..... Free-standing  
 Removable top: ..... No  
 Door hinge: ..... Right reversible  
 Color / Material body: ..... White  
 Length electrical supply cord: ..... 180.0 cm  
 Dimensions: ..... 842 x 598 x 613 mm  
 Net weight: ..... 55.2 kg  
 Drum volume: ..... 112 l  
 Fluorinated greenhouse gases: ..... No  
 Type of refrigerant: ..... R290  
 Hermetically sealed equipment: ..... Yes  
 Connection rating: ..... 600 W  
 Fuse protection: ..... 10 A  
 Voltage: ..... 220-240 V  
 Frequency: ..... 50 Hz  
 Drying process: ..... automatic  
 Loading capacity: ..... 9.0 kg  
 Energy efficiency class: ..... A+++  
 Energy consumption electric dryer, full load - NEW (2010/30/EC) 1.44 kWh  
 Standard cotton programme time at full load: ..... 260 min  
 Energy consumption electric dryer, partial load - NEW (2010/30/EC): ..... 0.80 kWh  
 Standard cotton programme time at partial load: ..... 156 min  
 Weighted annual energy consumption, electric dryer - NEW (2010/30/EC): ..... 174.0 kWh/annum  
 Power consumption in off-mode - NEW (2010/30/EC): ..... 0.30 W  
 Power consumption in left-on mode - NEW (2010/30/EC): ..... 0.30 W  
 Duration of the left-on mode - NEW (2012/30/EC): ..... 15 min  
 Weighted programme time: ..... 201 min  
 Condensation efficiency class - NEW (2010/30/EC): ..... A  
 Average condensation efficiency full load (%): ..... 91 %  
 Average condensation efficiency partial load (%): ..... 91 %  
 Weighted condensation efficiency for the standard cotton programme at full and partial load: ..... 91 %

---

WMZ20600 Wool in basket - accessory  
 WTZ27500 Stacking kit with pull-out shelf  
 WTZ27510 Stacking kit  
 WTZPW20D Platform with pull-out, dryer, cubic



## Series 8, heat pump dryer, 9 kg WQB246C9GB

---

### engine power and consumption

#### Programmes

- standard programmes: cotton, easy care
- Special programmes: App, Cotton, Bed linens, shirts/blouses, Cotton Eco, Delicates, Towels, Hygiene, Iron Assist/smartFinish, Mixed Load, Silent Dry, Sportswear, Synthetic, Timed Program Warm

#### options

- Anti crease cycle 120 min at the end of the programme
- Touch control buttons: 1 shirt, 5 shirts, basic setup, Iron dry, Business, Cupboard dry, Cupboard dry+, end time delay, Half load, Child lock, less ironing, myFavorite, Power button, Remote Start, Low Heat, smartDry/IntelligentDry, Start / Reload / Pause, speedPerfect/varioSpeed, 24 h end time delay

#### comfort and safety

- selfCleaning Condenser
- AutoDry technology
- Sensitive Drying System: Big Stainless steel drum with textile care structure, soft design paddles
- AntiVibration Design: more stability and quietness
- Drum interior light: LED
- Drain Set
- Child-proof lock
- Buzzer to indicate the end of cycle
- Door hinge: right-hand, door hinge: reversible
- Metal door closing hook

#### Technical Information

- Slide-under height of 85cm
- Dimensions (H x W): 84.2 cm x 59.8 cm
- Appliance depth: 61.3 cm
- Appliance depth incl. door: 65.1 cm
- Appliance depth with open door: 110.5 cm
- Heat pump technology with eco-friendly cooling agent R290

**Series 8, heat pump dryer, 9 kg**  
**WQB246C9GB**

Measurements in mm

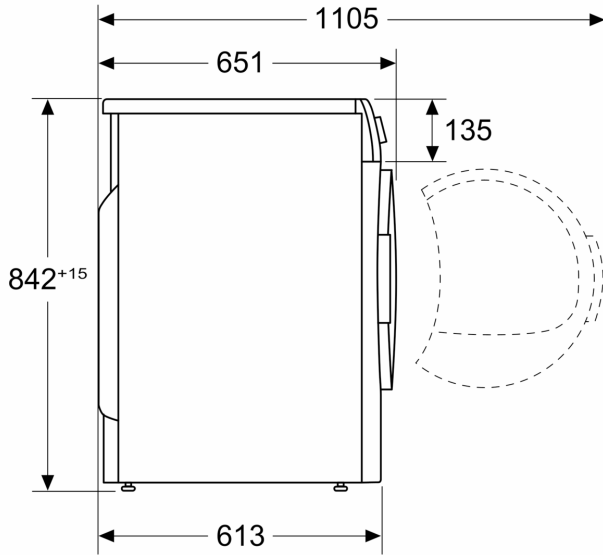

Measurements in mm

