

**Series 8, washing machine,  
frontloader fullsize, 9 kg, 1400 rpm  
WAV28MH4GB**



**The Serie|8 washer with Home Connect, with 4 AntiStain programmes and 4D Wash System with Intensive Plus provides spotless results with every load fully automatic.**

- **AntiStain:** reliably removes up to 4 most common stains (blood, butter/oil, grass, red wine).
- **4D Wash System:** highly efficient water and detergent fabric penetration for spotless results.
- **Home Connect:** home appliances with smart connectivity for an easier everyday life.
- **EcoSilence Drive™:** extremely energy-efficient and quiet in operation with a 10-year warranty.
- **Allergy Plus:** developed for allergy sufferers and people with sensitive skin.



- WMZPW20W Platform with pull-out, washer, cubic
- WMZ2200 Floor securing component
- WMZ2381 Extension for cold water inlet /Aquastop

Built-in / Free-standing: ..... Free-standing  
 Door hinge: ..... Left  
 Color / Material body: ..... White  
 Length electrical supply cord: ..... 210.0 cm  
 Height of the appliance: ..... 848 mm  
 Dimensions of the product: ..... 848 x 598 x 590 mm  
 Wheels: ..... No  
 Net weight: ..... 72.6 kg  
 Drum volume: ..... 65 l  
 Door Frame: ..... Chrome, white  
 Noise level washing: ..... 48 dB(A) re 1 pW  
 Connection rating: ..... 2300 W  
 Fuse protection: ..... 10 A  
 Voltage: ..... 220-240 V  
 Frequency: ..... 50 Hz  
 Energy Star Qualified: ..... No  
 Cord included: ..... Yes  
 Plug type: ..... GB plug  
 Length of supply hose (in): ..... 59.05 "  
 Dimensions of the packed product: ..... 34.44 x 25.19 x 26.57  
 Net weight: ..... 160.000 lbs  
 Gross weight: ..... 162.000 lbs  
 Length of drain hose: ..... 150.00 cm  
 Length of supply hose: ..... 150.00 cm  
 Dimensions of the packed product (HxWxD): ..... 875 x 675 x 640 mm  
 Gross weight: ..... 73.6 kg  
 Connection rating: ..... 2300 W  
 Fuse protection: ..... 10 A  
 Voltage: ..... 220-240 V  
 Frequency: ..... 50 Hz  
 Water protection system: ..... Multiple water protection  
 Maximum spin speed: ..... 1400 rpm  
 Spin speed options: ..... Variable  
 Digital countdown indicator: ..... Yes  
 Progress indicator: ..... LED-display  
 Energy Efficiency Class (Regulation (EU) 2017/1369): ..... A  
 Weighted energy consumption in kWh per 100 washing cycles of eco 40-60 programme (EU 2017/1369): ..... 48 kWh  
 Maximum capacity in kg (EU 2017/1369): ..... 9.0 kg  
 The water consumption of the eco programme in liters per cycle (EU 2017/1369): ..... 48 l  
 Duration of eco 40-60 programme in hours and mins at rated capacity (EU 2017/1369): ..... 3:44 h  
 Spin-drying efficiency class of eco 40-60 programme (EU 2017/1369): ..... B  
 Airborne acoustical noise emission class (EU 2017/1369): ..... A  
 Airborne acoustical noise emissions (EU 2017/1369): ..... 69 dB(A) re 1 pW



## Series 8, washing machine, frontloader fullsize, 9 kg, 1400 rpm WAV28MH4GB

**The Serie|8 washer with Home Connect,  
with 4 AntiStain programmes and 4D Wash  
System with Intensive Plus provides  
spotless results with every load fully  
automatic.**

### engine power and consumption

- Energy Efficiency Class<sup>1</sup>: A
- Energy<sup>2</sup> / Water<sup>3</sup>: 48 kWh / 48 litres
- Load capacity: 1 - 9 kg
- Programme duration<sup>4</sup>: 3:44 h:min
- Spin drying efficiency class: B
- Spin power / spin speed<sup>\*\*</sup>: 400 - 1400 U/min
- Noise level: 69 dB (A) re 1 pW
- Noise efficiency class: A

### Programmes

- standard programmes: cottons, easy care, delicate/silk, wool / hand wash
- Special programmes: allergy plus, Drum Clean (with reminder), shirts/blouses, Jeans / Dark wash, Spin / Drain, Family Mix, sportswear, single rinse, Quick 15'/30'

### options

- Home Connect: Remote Monitoring and Control, iService Remote, energy management photovoltaic
- Stain automatic – 4 stain removal options at the touch of a button
- TouchControl buttons: On/off, end time delay, stain selection, Intensive Plus, Rinse plus, Remote Start, start/pause with reload function, Temperature, SpeedPerfect, Prewash, Spin speed selection/Rinse hold

### comfort and safety

- Reload function: Be flexible in adding laundry items even after start of the wash cycle.
- Large LED-Display for programme status indication, temperature selection, max. spin speed, remaining time and 24 h end time delay, stain selection and consumption indication
- 4D Wash System: high efficient water and detergent fabric penetration for spotless results.
- XXL Drum volume: 65 l
- Drum interior light: LED
- VarioDrum: gentle and efficient washing
- DrumClean with reminder function
- 32 cm porthole, chrome, white with 171° opening door
- Reload function / pause function
- EcoSilence Drive: quiet motor with long lifetime
- 10 years guaranty on EcoSilence Drive
- ActiveWater Plus: for highly efficient use of water even with small loads thanks to automatic load detection.
- AntiVibration Design: more stability and quietness
- Sound insulation by bottom cover
- Sound insulation by additional damping material
- Multiple water protection

- Consumption Indication: Information about energy and water consumption
- control dial with integrated On-/Off mode
- Foam detection system to remove excessive foam
- Overdosage indication
- Unbalanced load detection
- Child-proof lock
- Buzzer at the end of the programme
- Easy cleaning detergent drawer
- Divider for Liquid Detergent

### Technical Information

- Slide-under height of 85cm
- Dimensions (H x W): 84.8 cm x 59.8 cm
- Appliance depth: 59.0 cm
- Appliance depth incl. door: 63.2 cm
- Appliance depth with open door: 106.3 cm

<sup>1</sup> Scale of Energy Efficiency Classes from A to G

<sup>2</sup> Energy consumption in kWh per 100 cycles (in programme Eco 40-60)

<sup>3</sup> Weighted water consumption in litres per cycle (in programme Eco 40-60)

<sup>4</sup> Duration of programme Eco 40-60

\*\* Values are rounded.

**Series 8, washing machine,  
frontloader fullsize, 9 kg, 1400 rpm  
WAV28MH4GB**

---

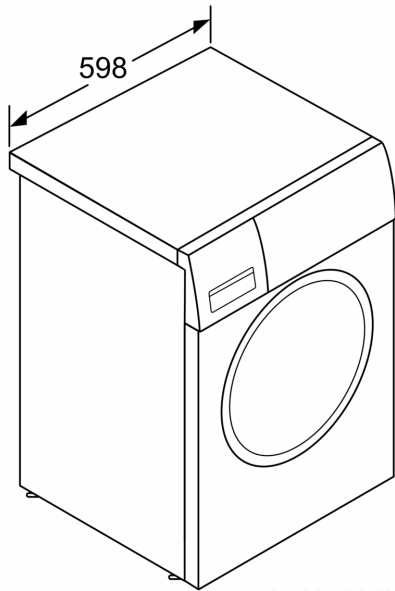

measurements in mm

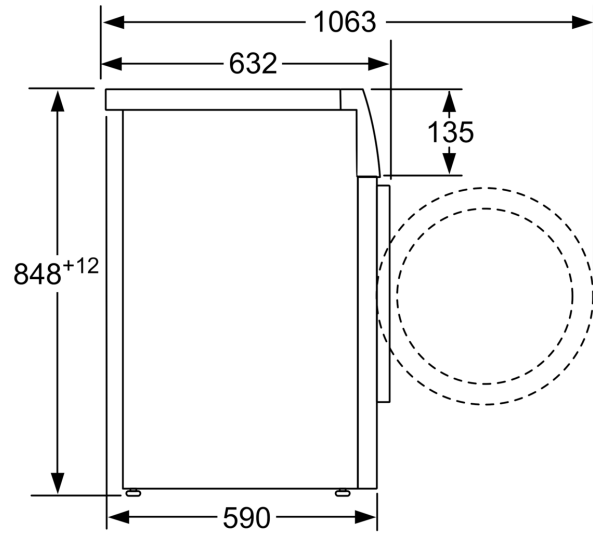

measurements in mm