

Series 2, fully-integrated dishwasher, 45 cm SPV2HKX41E



SGZ0BI02	decorative strips stainless steel 81,5cm
SGZ1010	inlet and outlet hose extension
SMZ1051EU	Mains cable with EU-Plug 5m
SMZ5000	Dishwashing aid set
SMZ5002	Silver polishing cassette
SMZ5003	Retractable hinge f. high corpus dimens.
SMZ5300	GlassSecure Tray

- **ExtraDry:** selectable option for additional drying.
- **Home Connect:** home appliances with smart connectivity for an easier everyday life.
- **Favourite function:** personalized function by just one touch.
- **InfoLight:** a red infolight on the floor indicates whether the dishwasher is switched on or off.
- **AquaStop:** Bosch's warranty in case of water damage – throughout the lifetime of the appliance.*

Energy Efficiency Class (Regulation (EU) 2017/1369): E
Energy Consumption for 100 cycles Eco Programme: 70 kWh
Maximum number of place settings: 9
The water consumption of the eco programme in liters per cycle:	8.5 l
Programme duration: 3:40 h
Airborne acoustical noise emissions :46 dB(A) re 1 pW
Airborne acoustical noise emission class:C
Cleaning performance:A
Water consumption:8.5 l
Total annual energy consumption 220 days: 170 kWh
Total annual water consumption 220 days: 1870 l
Built-in / Free-standing: Built-in
Removable top: No
Door panel options: Not possible
Height of removable worktop: 0 mm
Height of the appliance: 815 mm
Adjustable feet: Yes - all from front
Maximum adjustability feet: 60 mm
Adjustable plinth: Both horizontal and vertical
Net weight: 27.7 kg
Gross weight: 29.5 kg
Connection rating: 2400 W
Fuse protection:10 A
Voltage: 220-240 V
Frequency: 50; 60 Hz
Length electrical supply cord: 175.0 cm
Plug type: Gardy plug w/ earthing
Length inlet hose: 165 cm
Length outlet hose: 205 cm
Hidden heating element: Yes
Water protection system description: Triple water protection 24h
Child safety devices: No
Water softener:Yes
Top basket type: R2
Adjustable upper basket: Single
Bottom basket type: R2
3rd Rack: None
Optional accessories: . SGZ0BI02, SGZ1010, SMZ1051EU, SMZ5000, SMZ5002, SMZ5003, SMZ5300	
Included accessories 2: Vapor barrier plate
Number of place settings:9
Dimensions of the product (HxWxD):815 x 448 x 550 mm
Dimensions of the packed product (HxWxD): 880 x 510 x 670 mm



Series 2, fully-integrated dishwasher, 45 cm SPV2HKX41E

BOSCH - Header 1

- Home Connect enabled via WLAN

BOSCH - Header 2

- 5 programmes: Eco 50 °C, Auto 45-65 °C, Intensive 70 °C, Express 65 °C, Pre-Rinse
- Favourite Program
- 3 special options: Remote Start, Extra Dry, SpeedPerfect+
- Machine Care
- Silence on Demand (via app)

BOSCH - Header 3

- Heat exchanger.
- AquaSensor
- DosageAssist
- EcoSilence Drive
- DuoPower spray arms in top basket
- Detergent Automation
- Self-cleaning filter system with 3-fold corrugated filter
- Interior tub material: Stainless Steel

BOSCH - Header 4

- Vario basket system
- Low friction wheels on bottom basket
- Rack Stopper to prevent derailing of bottom basket
- Height adjustable top basket
- 2 foldable plate racks in bottom basket
- Cutlery rack in top basket
- Variable cutlery basket in bottom basket
- 2 cup shelves in top basket

BOSCH - Header 5

- Push button top controls
- Panel legend: Plain text (english)
- InfoLight (red)

BOSCH - Header 6

- AquaStop: Bosch warranty in case of water damage – for the lifetime of the appliance.*
- Glass protection technology
- incl. salt filling funnel
- Incl. Steam protection plate

BOSCH - Header 7

- Product dimensions (HxWxD): 81.5 x 44.8 x 55 cm

BOSCH - Header 8

* Please find warranty terms under [please insert here the local URL (internet address, e.g. <https://www.bosch-home.com/> but with the direct page with the warranty terms)

**Series 2, fully-integrated dishwasher,
45 cm
SPV2HKX41E**

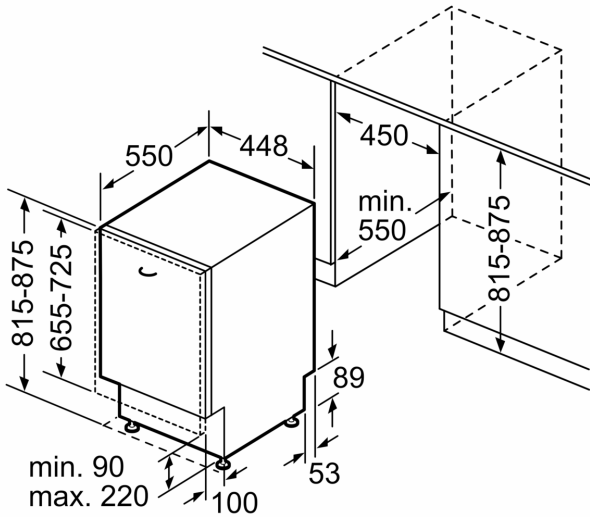

measurements in mm

measurements in mm

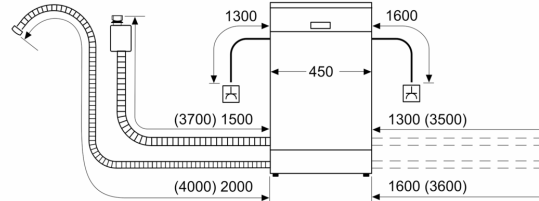

⏏ socket
() values with extension kit