

Series 8, Flex induction hob, 90 cm, , PXV975DC1E

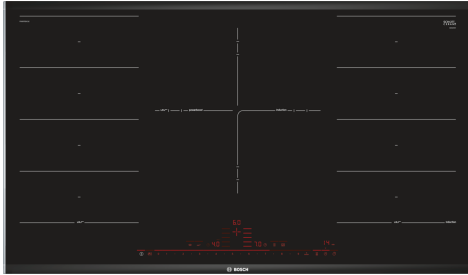

HEZ32WA00 Wireless food thermometer, HEZ390011 Stainless Steel roaster with glas lid, HEZ390012 Steaming Rack for Stainless Steel roaste, HEZ390090 Wok Set consisting of 3 Items, HEZ390210 System pan diameter 15 cm, HEZ390220 System pan diameter 19 cm, HEZ390230 System pan diameter 21cm, HEZ390512 Teppan Yaki (large), HEZ390522 Griddle Plate, HEZ394301 Connecting strip, HEZ9ES100 Espresso maker 4 cups, HEZ9FE280 Iron pan Ø 18 / 28 cm, HEZ9FF010 Flex Pan, large, HEZ9FF030 Flex Pan set, 3 pcs., HEZ9FF040 Flex Pan set, 4 pcs., HEZ9SE040 4 pieces Set, HEZ9SE060 6 pieces Set, HEZ9TY010 Teppan Yaki, HZ390011 Stainless Steel roaster with glas lid

- **DirectSelect Premium:** Direct, simple selection of the desired cooking zone, power and additional functions.
- **FlexInduction Zone:** Get more flexibility by combining the cooking zones into one big zone for placing small pots and large cookware.
- **PerfectFry:** For perfect browning of roasted foods thanks to sensor control with 5 power levels.
- **ComfortProfile:** Elegant, appealing design with bevelled front and metal strips on the side.
- **MoveMode:** the automatic setting of cooking levels allows fast boiling on the front, cooking on the middle and simmering on the rear cooking zone.

Product name/family: Cooking zone ceramic
 Built-in / Free-standing: Built-in
 Energy input: Electric
 Total number of positions that can be used at the same time: 5
 Min. required niche size for installation (HxWxD): 51 x 880-880 x 490-500 mm
 Width of the appliance: 916 mm
 Dimensions: 51 x 916 x 527 mm
 Dimensions of the packed product (HxWxD): ... 126 x 1073 x 603 mm
 Net weight: 20.0 kg
 Gross weight: 23.8 kg
 Residual heat indicator: yes
 Location of control panel: Front
 Basic surface material: Ceramic
 Color of surface: Black, Alu, brushed
 Length electrical supply cord: 110.0 cm
 Sealed Burners: No
 Power Boost: All cooking zones
 Power of 2nd heating element (kW): 3.3 kW
 Power of heating element (kW in boost): [3.7] kW
 Power of 6th heating element (kW in boost): 3.7 kW
 Connection rating: 11100 W
 Voltage: 220-240 V
 Frequency: 60; 50 Hz
 Energy input: Electric
 Plug type: No plug (electrical connection by electrician)
 Appliance Dimensions (h x w x d) (in): x x
 Dimensions of the packed product: 4.96 x 23.74 x 42.26
 Net weight: 44.000 lbs
 Gross weight: 52.000 lbs
 Total number of positions that can be used at the same time: 5
 Length electrical supply cord: 110.0 cm
 Min. required niche size for installation (HxWxD): 51 x 880-880 x 490-500 mm
 Dimensions: 51 x 916 x 527 mm
 Dimensions of the packed product (HxWxD): ... 126 x 1073 x 603 mm
 Net weight: 20.0 kg
 Gross weight: 23.8 kg



Series 8, Flex induction hob, 90 cm, , PXV975DC1E

measurements in mm

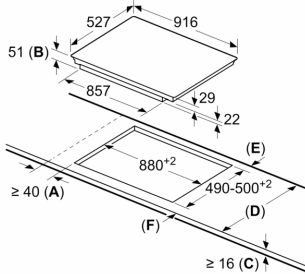

- A: Minimum distance from the hob cut-out to the wall.
- B: Recessed depth
- C: The clearance between the surface of the worktop and the top of the front of the oven must be 30 mm. See space requirements for the oven.

The worktop into which the hob is installed must withstand loads of approx. 60 kg; suitable substructures must be used if required.

D	E	F
585-600	50	≥ 35
> 600	≥ 50	≥ 50

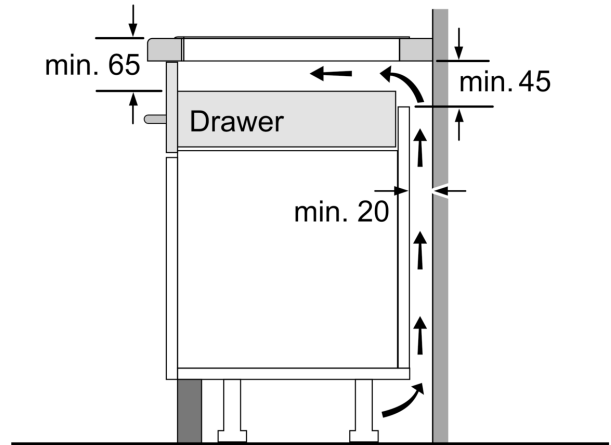

Measurements in mm

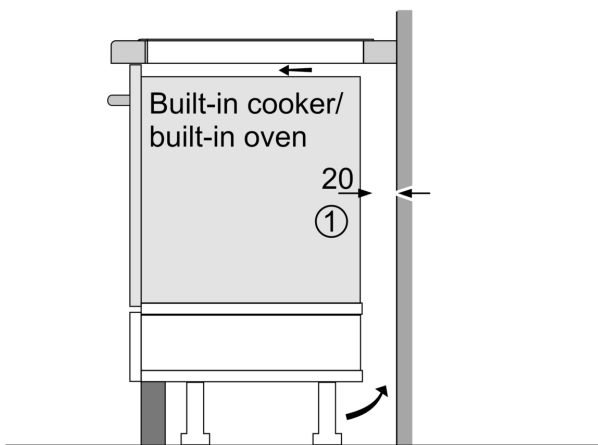

- ① Ventilation gap must be present.

Measurements in mm

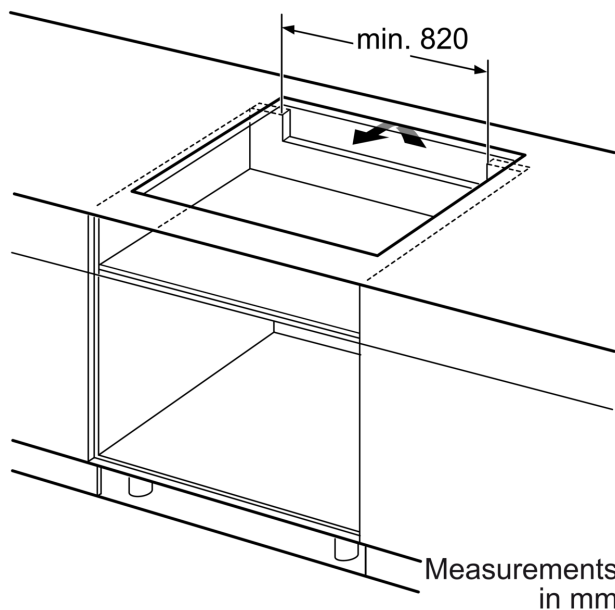

Measurements in mm