

Series 4, free-standing fridge-freezer with freezer at bottom, 203 x 70 cm, Brushed steel anti-fingerprint KGN497ICT



- **VitaFresh XXL:** keeps food fresh for longer in extra-large climate controlled drawers at near $<0^{\circ}\text{C}>$.
- **FlexShelf:** more space if needed with retractable shelf.
- **Perfect Fit:** place your fridge right next to walls or in a niche.
- **LED Lighting:** keep your groceries in perfect view.
- **2 Cooling Systems:** separately controllable refrigerator and freezer compartments

Energy Efficiency Class (Regulation (EU) 2017/1369): C
Average annual energy consumption in kilowatt hour per year (kWh/a): 178 kWh/annum
Sum of volume of frozen compartments: 129 l
Sum of volume of chill compartments: 311 l
Airborne acoustical noise emissions :35 dB(A) re 1 pW
Airborne acoustical noise emission class:B
Built-in / Free-standing: Free-standing
Number of compressors: 1
Number of independent cooling systems: 2
Width of the appliance: 700 mm
Height: 2030 mm
Depth of the product: 667 mm
Net weight:81.5 kg
Door panel options: Not possible
Door hinge: Right reversible
Number of Adjustable Shelves in fridge compartment: 3
Shelves for Bottles: Yes
Frost free system: Fridge and freezer
Interior ventilator: No
Reversible Door Hinge: Yes
Length electrical supply cord: 226.0 cm
Noise level:35 dB(A) re 1 pW
Multi-Flow Air Tower: Yes
Fast cooling switch:Yes
Fast freezing switch:Yes
Temperature Controlled Drawer: No
Humidity Control Drawer:No
Number of Door Bins - Refrigerator:4
Door bin adjustability - Refrigerator: Yes
Tilt-out door bins in fridge:No
Gallon wide door bins: Yes
Number of Gallon storage: 1
Motorized Shelf: No
Material of the shelves: Safety glass
Door opened indicator freezer:No
Automatic motor-driven ice-maker:No
Fuse protection:10 A
Voltage: 220-240 V
Frequency: 50 Hz
Storage Period in Event of Power Failure (h): 18 h
Door panel options: Not possible
Noise level:35 dB(A) re 1 pW
Energy Star Qualified:No
Plug type: Gardy plug w/ earthing
Required cutout/niche size for installation (in):x
Dimensions of the packed product: 82.48 x 29.92 x 30.70
Net weight:180.000 lbs
Gross weight: 195.000 lbs



Series 4, free-standing fridge-freezer with freezer at bottom, 203 x 70 cm, Brushed steel anti-fingerprint KGN497ICT

- inox EasyClean Doors

Performance and consumption

- EU19_EEK_D: C
- Total Volume : 440 l
- Net Fridge Volume : 311 l
- Net Freezer Volume : 129 l
- Freezing capacity 24h : 11 kg
- Annual Energy Consumption: 178 kWh/a
- Climate Class: SN-T
- yes
- Noise Level : 35 dB
- Temperature rise time : 18 H

Design and Styling

- Doors inox EasyClean, side panels Pearl grey (VZF 07127)
- Plastic backwall
- vertical handle
- LED with Soft Start in fridge section

Convenience & Safety

- Separate, electronic temperature control, LED indicators
- Two Cooling Systems
- Super Cooling: automatic deactivation
- Optical and acoustic door open warning system
- Visual / acoustic

Fridge Compartment

- Multi Airflow-System
- 5 safety glass shelves (3 height adjustable), of which 1 Dividable glass shelf
- 5 safety glass shelves of which 3 are height adjustable
- Bottle grid
- 1 door shelf large, 3 door shelf small
- 4 door bins

Freshness System

- 1 VitaFresh drawer with humidity control - Fruits and vegetables retain vitamins and stay fresh for longer.
- , 1 VitaFresh 0°C drawer - Fish and meat stay fresh for longer

Freezer Section

- 3 transparent freezer drawers

Dimensions

- Dimensions (H x W x D): 203.0 cm x 70.0 cm x 66.7 cm

Technical Information

- Door right hinged, reversible
- Height adjustable front feet
- Nominal voltage: 220 - 240 V

Accessories

- egg tray
- ice cube tray

Country Specific Options

- Based on the results of the standard 24-hour test. Actual consumption depends on usage/position of the appliance.

Environment and Safety

Installation

General Information

- Super Freezing: Manual/automatic activation

**Series 4, free-standing fridge-freezer
with freezer at bottom, 203 x 70 cm,
Brushed steel anti-fingerprint
KGN497ICT**

Measurements in mm

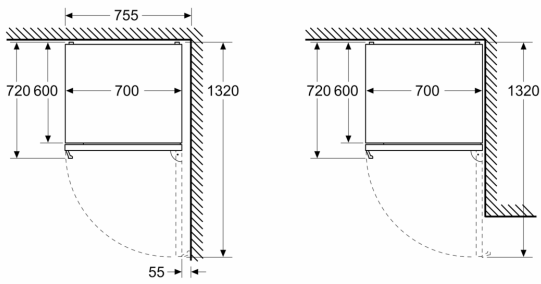

Measurements in mm

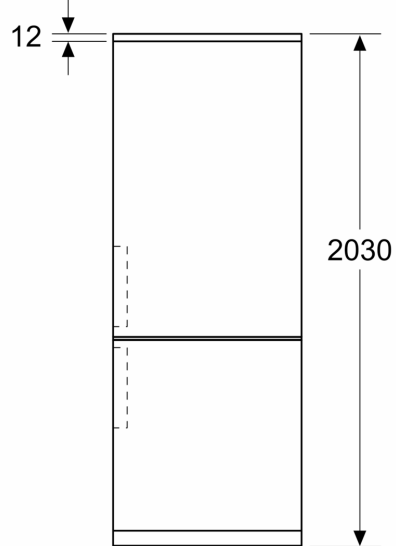

Measurements in mm

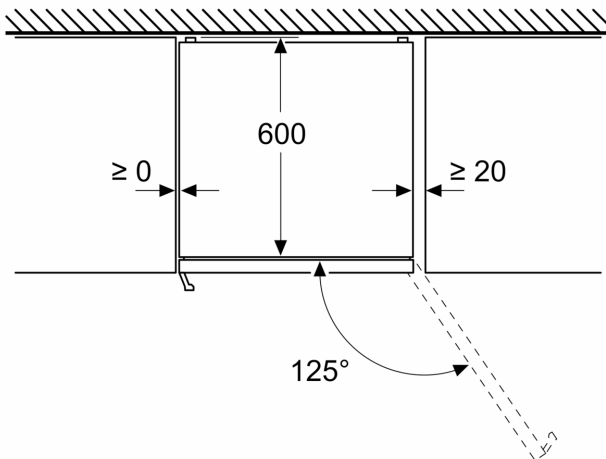

Measurements in mm

