

**Series 6, free-standing fridge-freezer with freezer at bottom, 203 x 60 cm, Stainless steel (with anti-fingerprint) KGN394ICF**



- **VitaFresh XXL:** keeps food fresh for longer in extra-large climate controlled drawers at near  $<0^{\circ}\text{C}>$ .
- **LED Lighting:** keep your groceries in perfect view.
- **2 Cooling Systems:** separately controllable refrigerator and freezer compartments
- **Super Cooling function:** cools new food placed inside faster, thus protecting already cooled food.
- **Perfect Fit:** place your fridge right next to walls or in a niche.

Energy Efficiency Class (Regulation (EU) 2017/1369):	..... C
Average annual energy consumption in kilowatt hour per year (kWh/a) (EU) 2017/1369:	..... 162 kWh/annum
Sum of volume of frozen compartments (EU 2017/1369):	..... 103 l
Sum of volume of chill- and unfrozen compartments (EU 2017/1369):	..... 260 l
Airborne acoustical noise emissions (EU 2017/1369):	..... 35 dB(A) re 1 pW
Airborne acoustical noise emission class (EU 2017/1369):	..... B
Built-in / Free-standing:	..... Free-standing
Number of compressors:	..... 1
Number of independent cooling systems:	..... 2
Width of the appliance:	..... 600 mm
Height:	..... 2030 mm
Depth of the product:	..... 665 mm
Net weight:	..... 73.7 kg
Door panel options:	..... Not possible
Door hinge:	..... Right reversible
Number of Adjustable Shelves in fridge compartment:	..... 3
Shelves for Bottles:	..... Yes
Frost free system:	..... Freezer
Interior ventilator:	..... No
Reversible Door Hinge:	..... Yes
Length electrical supply cord:	..... 226.0 cm
Noise level:	..... 35 dB(A) re 1 pW
Multi-Flow Air Tower:	..... Yes
Fast cooling switch:	..... Yes
Fast freezing switch:	..... Yes
Temperature Controlled Drawer:	..... No
Humidity Control Drawer:	..... No
Number of Door Bins - Refrigerator:	..... 4
Door bin adjustability - Refrigerator:	..... Yes
Tilt-out door bins in fridge:	..... No
Gallon wide door bins:	..... Yes
Number of Gallon storage:	..... 1
Motorized Shelf:	..... No
Material of the shelves:	..... Safety glass
Door opened indicator freezer:	..... No
Automatic motor-driven ice-maker:	..... No
Fuse protection:	..... 10 A
Voltage:	..... 220-240 V
Frequency:	..... 50 Hz
Storage Period in Event of Power Failure (h):	..... 15 h
Door panel options:	..... Not possible
Noise level:	..... 35 dB(A) re 1 pW
Energy Star Qualified:	..... No
Plug type:	..... GARDY plug w/ earthing
Required cutout/niche size for installation (in):	..... X
Dimensions of the packed product:	..... 82.48 x 25.98 x 30.70
Net weight:	..... 162.000 lbs
Gross weight:	..... 176.000 lbs



**Series 6, free-standing fridge-freezer  
with freezer at bottom, 203 x 60 cm,  
Stainless steel (with anti-fingerprint)  
KGN394ICF**

Measurements in mm

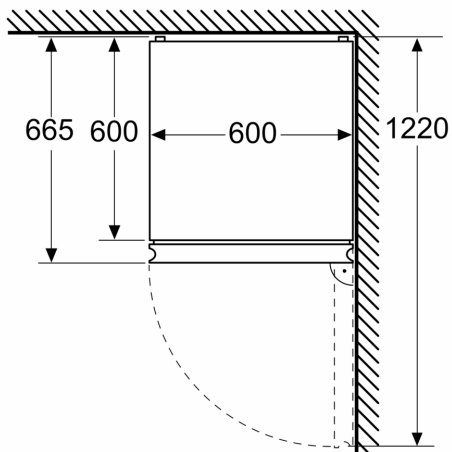

Measurements in mm

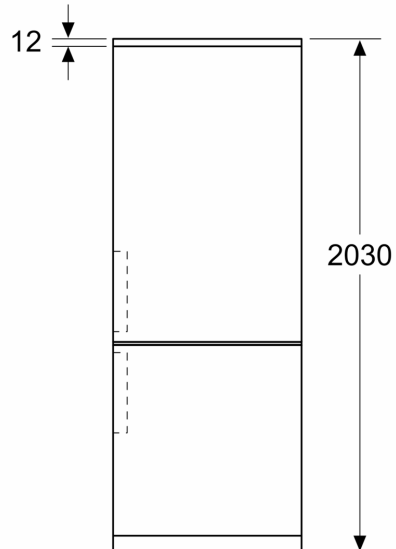

Measurements in mm

