

**Series 6, built-under freezer, 82 x 59.8 cm, soft close flat hinge  
GUD15ADF0**



1 x ice cube tray

KFZ10AX0 Door panel with decor frame  
KUZ20SX0 Attachment door, stainless steel

**The freezer with 3 transparent freezer drawers and SuperFreezing: freezes new items placed inside even faster.**

- **Super Freezing function:** Protects frozen food from defrosting.

Energy Efficiency Class (Regulation (EU) 2017/1369): ..... F  
 Average annual energy consumption in kilowatt hour per year (kWh/a): ..... 224 kWh/annum  
 Sum of volume of frozen compartments: ..... 106 l  
 Airborne acoustical noise emissions : .....38 dB(A) re 1 pW  
 Airborne acoustical noise emission class: .....C  
 Product category: ..... Upright freezer  
 Built-in / Free-standing: ..... Built-in  
 Frost free system: .....No  
 Climate class: ..... SN-ST  
 Door panel options: ..... Possible but accessory  
 Width of the appliance: ..... 598 mm  
 Depth of the product: ..... 548 mm  
 Dimensions of the packed product (HxWxD): ..... 890 x 670 x 620 mm  
 Warning signal / malfunction: ..... Both visual and audible  
 Defrost process: ..... manual  
 Cover door installation system: ..... Fixed-mounted  
 Number of drawers/baskets (Stck): ..... 3  
 Number of freezing flaps (Stck): .....0  
 Lockable door: ..... No  
 Thermometer freeze section: .....Analog  
 Light: ..... No  
 Length electrical supply cord: ..... 230.0 cm  
 Door hinge: ..... Right reversible  
 Net weight: ..... 37.1 kg  
 Gross weight: ..... 40.0 kg  
 Multi-Flow Air Tower: ..... No  
 Number of compressors: ..... 1  
 Number of independent cooling systems: ..... 1  
 Economy setting: ..... No  
 Fast freezing switch: .....Yes  
 Door bin adjustability - Freezer: ..... No  
 Tilt-out door bins in freezer: ..... No  
 Door bin adjustability - Freezer: ..... No  
 Reversible Door Hinge: ..... Yes  
 Connection rating: ..... 90 W  
 Fuse protection: .....10 A  
 Frequency: ..... 50 Hz  
 Door panel options: ..... Possible but accessory  
 Installation typology: ..... Built-under  
 Noise level: .....38 dB(A) re 1 pW  
 Energy Star Qualified: .....No  
 Plug type: ..... GARDY plug w/ earthing  
 Required cutout/niche size for installation (in): .....x  
 Dimensions of the packed product: ..... 35.03 x 26.37 x 24.40  
 Net weight: .....82.000 lbs  
 Gross weight: ..... 88.000 lbs  
 Included accessories: .....1 x ice cube tray



**Series 6, built-under freezer, 82 x  
59.8 cm, soft close flat hinge  
GUD15ADF0**

**The freezer with 3 transparent freezer  
drawers and SuperFreezing: freezes new  
items placed inside even faster.**

---

**Special Accessories**

- KFZ10AX0, KUZ20SX0

**Performance and consumption**

**Design and Styling**

- Combined to Fridge/Freezer combination

**Convenience & Safety**

- Flat hinge
- Electromechanical temperature control
- Visual / acoustic
- Super Freezing: manual activation

**Freezer Section**

- 3 transparent freezer drawers

**Dimensions**

- Dimensions ( H x W x D): 82.0 cm x 59.8 cm x 54.8 cm
- Niche Dimension (H x W x D): 82.0 cm x 60.0 cm x 55.0 cm

**Technical Information**

- Door right hinged, reversible
- Connected load: 90 W
- Nominal voltage: 220 - 240 V

**Accessories**

- ice cube tray

**Country Specific Options**

- Based on the results of the standard 24-hour test. Actual consumption depends on usage/position of the appliance.

**Environment and Safety**

**Installation**

**Series 6, built-under freezer, 82 x 59.8 cm, soft close flat hinge  
GUD15ADF0**

measurements in mm

Recommended gap dimension

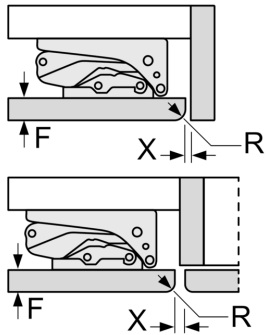

F
16-19
20
21
22

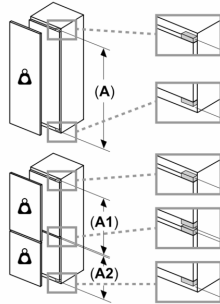

**Maximal permissible**

Fitted unit fronts that e) cause damage and res hinges

Δ Weight

A: Appliance door heig

B: Undamped hinge, u

C: Damped hinge, unit

D: Additional possible l

A	B
1500-1750	22
720-1400	19
A1	15
A2	15

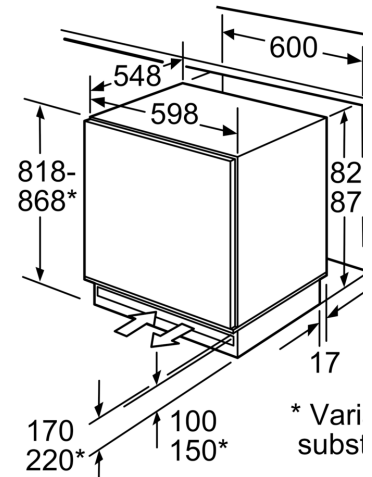

Space for electrical connector the appliance on the left or right  
Ventilation space in the base.  
meas

The gap dimensions recomme in the table must be adhered to to ensure that appliance doors collide with anything when the and to avoid causing damage