

**Series 6, built-in freezer, 177.2 x
55.8 cm, flat hinge
GIN81AEF0**



**The NoFrost freezer with electronic
temperature control: set the target
temperature precisely and easily.**

- **VarioZone:** more flexibility due to variable-use glass shelves and drawers in the freezer compartment.
- **NoFrost:** never defrost again, thanks to perfect protection from ice formation - that saves time and effort.
- **BigBox frozen food drawer:** for stacking storage containers or for large frozen food items.
- **VarioInverter works by adjusting to the changes in temperatures inside and outside the refrigerator and the load within and provides optimal performance* during voltage fluctuations.**



1 x ice cube tray

KSZB0S00 Heavy-duty hinge support

Energy Efficiency Class (Regulation (EU) 2017/1369): F
 Average annual energy consumption in kilowatt hour per year
 (kWh/a) (EU) 2017/1369:294 kWh/annum
 Sum of volume of frozen compartments (EU 2017/1369): 212 l
 Airborne acoustical noise emissions (EU 2017/1369): .36 dB(A) re 1
 pW
 Airborne acoustical noise emission class (EU 2017/1369): C
 Product category: Upright freezer
 Built-in / Free-standing: Built-in
 Frost free system: Fridge and freezer
 Climate class: SN-T
 Door panel options: Not possible
 Width of the appliance: 558 mm
 Depth of the product: 545 mm
 Dimensions of the packed product (HxWxD): ... 1840 x 610 x 640 mm
 Warning signal / malfunction: Both visual and audible
 Defrost process: Automatic
 Cover door installation system: Fixed-mounted
 Number of drawers/baskets (Stck): 5
 Number of freezing flaps (Stck): 2
 Lockable door: No
 Thermometer freeze section: Digital
 Light: No
 Length electrical supply cord: 230.0 cm
 Door hinge: Left reversible
 Net weight: 65.6 kg
 Gross weight: 70.3 kg
 Multi-Flow Air Tower: No
 Number of compressors: 1
 Number of independent cooling systems: 1
 Economy setting: No
 Fast freezing switch: Yes
 Door bin adjustability - Freezer: No
 Tilt-out door bins in freezer: No
 Number of shelves - Freezer: 0
 Door bin adjustability - Freezer: No
 Shelf Material - Freezer: Safety glass
 Reversible Door Hinge: Yes
 Connection rating: 120 W
 Fuse protection: 10 A
 Frequency: 50 Hz
 Door panel options: Not possible
 Installation typology: Integrated
 Noise level: 36 dB(A) re 1 pW
 Energy Star Qualified: No
 Plug type: GARDY plug w/ earthing
 Required cutout/niche size for installation (in): x
 Dimensions of the packed product: 72.44 x 24.01 x 25.19
 Net weight: 145.000 lbs
 Gross weight: 155.000 lbs
 Included accessories: 1 x ice cube tray



**Series 6, built-in freezer, 177.2 x
55.8 cm, flat hinge
GIN81AEF0**

**The NoFrost freezer with electronic
temperature control: set the target
temperature precisely and easily.**

Performance and consumption

Convenience & Safety

- NoFrost - never again defrosting!
- Flat hinge
- 7 segment electronic control
- 1 compressor/1 cold circuit
- Super Freezing: Manual/automatic activation
- FreshSense - constant temperature by intelligent sensor technology
- Acoustic Warning System, Warning System by temperature increase

Freezer Section

- 5 transparent freezer drawers, incl. 2 x big box

Technical Information

- Door left hinged, reversible
- Connected load: 120 W
- Nominal voltage: 220 - 240 V

Dimensions

- Niche Dimension (H x W x D): 177.5 cm x 56.0 cm x 55.0 cm
- Dimensions (H x W x D): 177.2 cm x 55.8 cm x 54.5 cm

Accessories

- ice cube tray

Country Specific Options

- Based on the results of the standard 24-hour test. Actual consumption depends on usage/position of the appliance.

General Information

**Series 6, built-in freezer, 177.2 x 55.8 cm, flat hinge
GIN81AEF0**

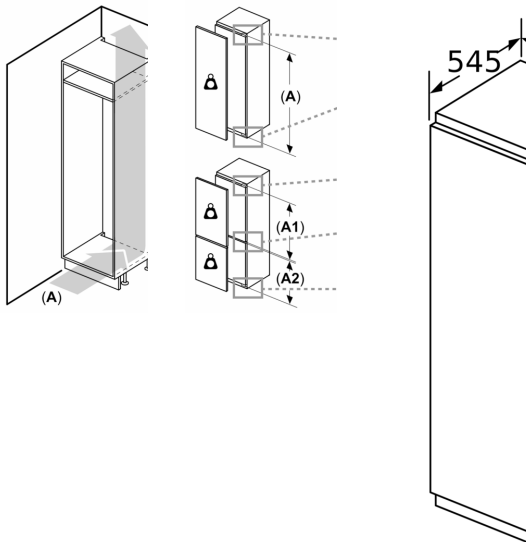

Air outlet
min. 200

Ventilatio
space
in the bas
min. 200

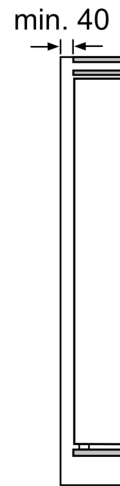

Maximal per

measur
Recomm

Fitted kitchen
weight may c
impairment c

T: Includes I
of appliance
Hinges in m
1500-1

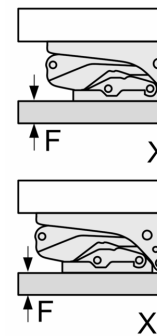

The gap di
in the table
to ensure th
collide with
and to avoi