

Series 8, Built-In Microwave, Black BFL634GB1



HEZ6UCC0 Cookbook
HEZG9AS00S Adapter

- **AutoPilot 7:** every dish is a perfect success thanks to 7 pre-set automatic programmes.
- **TFT Touch Display:** easy-to-use thanks to the Control Ring with clear text and symbols.
- **Stainless steel interior:** easy to clean interior thanks to smooth surfaces and no sharp edges.
- **Electronical door opening:** comfortable door opening just with a fingertip on the sensor button.

Type of control:Electronic
 Dimensions: 382 x 594 x 318 mm
 Cavity dimensions: 220 x 350 x 270 mm
 Length electrical supply cord: 150.0 cm
 Net weight: 16.7 kg
 Gross weight: 18.9 kg
 Max. microwave power level: 900 W
 Number of Power Levels: 5
 Turntable: No
 Cavity material: Stainless steel
 Door opening: Button
 Clock: Yes
 Height of the appliance: 382 mm
 Width of the appliance: 594 mm
 Depth of the product: 318 mm
 Max. microwave power level: 900 W
 Connection rating: 1220 W
 Fuse protection: 10 A
 Voltage: 220-240 V
 Frequency: 50; 60 Hz
 Plug type: Gardy plug w/ earthing
 Required cutout/niche size for installation (in):x
 Dimensions of the packed product: 18.50 x 18.11 x 26.37
 Net weight: 37.000 lbs
 Gross weight: 42.000 lbs



4 242002 813752

Series 8, Built-In Microwave, Black BFL634GB1

Microwave and heating mode:

- Max. Power: 900 W; 5 Microwave power settings: 90 W, 180 W, 360 W, 600 W, 900 W
- Intelligent inverter technology: maximum output power will be regulated to 600 W when used in longer operation
- Cavity volume: 21 l

Design:

- stainless steel cavity with glass bottom

Comfort:

- electronic clock
- Rotary swivel, Touch control
- User-friendly electronics: extremely
- easy and comfortable operation
- AutoPilot 7
- 3 defrost and 4 cooking programmes in microwave function
- LED light
- side opening door, hinge left
- Electronic door opener
- Touch key operation

Environment and Safety:

- Start-/Stop button
- Integral cooling fan

Technical Information

- Length of mains cable: 150 cm
- Total connected load electric: 1.22 KW
- Nominal voltage: 220 - 240 V
- Suitable for high cupboard installation, Can be built in a 60 cm wall cupboard (at least 30cm deep)

Dimensions:

- Appliance dimension (hxwx): 382 mm x 594 mm x 318 mm
- Niche dimension (hxwx): 362 mm - 382 mm x 560 mm - 568 mm x 300 mm
- "Please reference the built-in dimensions provided in the installation drawing"

**Series 8, Built-In Microwave, Black
BFL634GB1**

measurements in mm

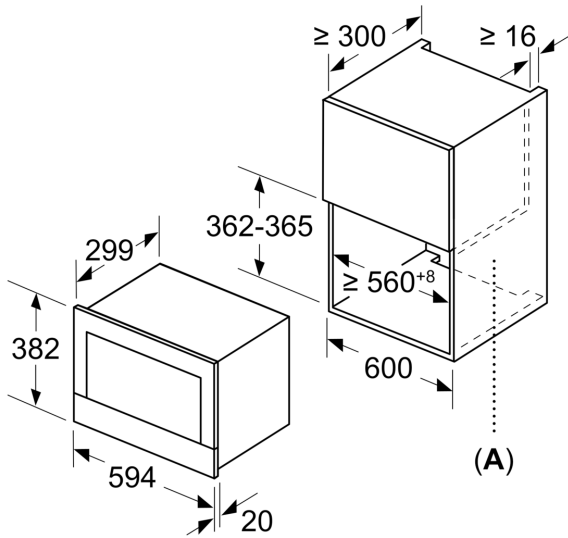

(A)

A: Back panel open

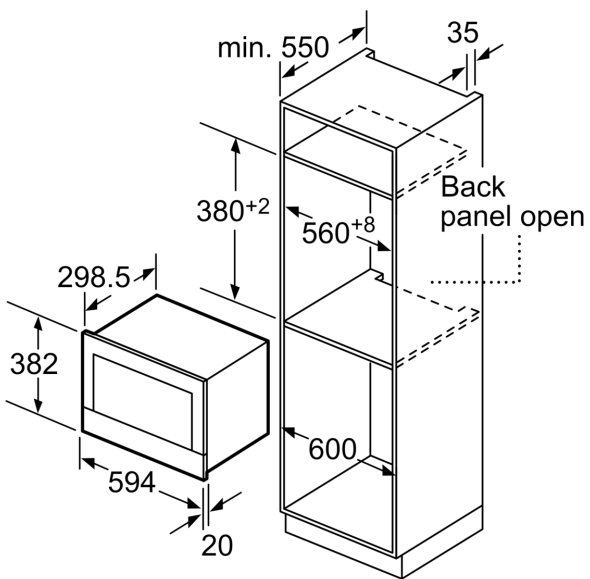
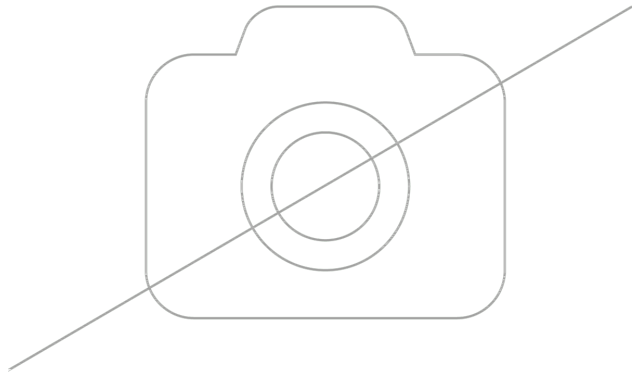

measurements in mm