

Series 6, Built-In Microwave, Stainless steel BFL524MS0



- **AutoPilot 7:** every dish is a perfect success thanks to 7 pre-set automatic programmes.
- **LED-display control, white:** easy-to-use thanks to direct access to additional functions.
- **Pop-out controls:** for an easy to clean front.
- **Stainless steel interior:** easy to clean interior thanks to smooth surfaces and no sharp edges.
- **Cleaning Assistance:** less cleaning effort thanks to the new cleaning option, which can be especially used for cleaning of light soiling.

1 x Turntable

HEZ86D000 Steamer Cooker Accessory for Microwave
HEZG9AS00S Adapter

Type of control:Electronic
Dimensions: 382 x 594 x 317 mm
Cavity dimensions: 201.0 x 308.0 x 282.0 mm
Length electrical supply cord: 130.0 cm
Net weight: 16.5 kg
Gross weight: 18.8 kg
Max. microwave power level: 800 W
Number of Power Levels: 5
Turntable: Yes
Cavity material: Stainless steel
Door opening: Button
Clock: Yes
Included accessories: 1 x Turntable
Height of the appliance: 382 mm
Width of the appliance: 594 mm
Depth of the product: 317 mm
Max. microwave power level: 800 W
Connection rating: 1270 W
Fuse protection: 10 A
Voltage: 220-230 V
Frequency: 50 Hz
Plug type: GARDY plug w/ earthing
Required cutout/niche size for installation (in): x
Dimensions of the packed product: 17.32 x 14.96 x 25.59
Net weight: 36.000 lbs
Gross weight: 41.000 lbs



Series 6, Built-In Microwave, Stainless steel BFL524MS0

Microwave and heating mode:

- Max. Power: 800 W; 5 Microwave power settings: 90 W, 180 W, 360 W, 600 W, 800 W
- Cavity volume: 20 l

Design:

- stainless steel cavity

Cleaning:

- Cleaning Assistance

Comfort:

- LED display control
- electronic clock
- Rotary Control, Pop-out controls, Touch control
- User-friendly electronics: extremely
- easy and comfortable operation
- AutoPilot 7
- 4 defrost and 3 cooking programmes in microwave function
- LED light
- side opening door, hinge left
- Electronic door opener
- Touch key operation

Accessory:

- Turntable

Environment and Safety:

- Automatic switch off
- Door contact switch
- Integral cooling fan

Technical Information

- Length of mains cable: 130 cm
- Total connected load electric: 1.27 KW
- Nominal voltage: 220 - 230 V
- Suitable for high cupboard installation, Can be built in a 60 cm wall cupboard (at least 30cm deep)

Dimensions:

- Appliance dimension (hxwxd): 382 mm x 594 mm x 317 mm
- Niche dimension (hxwxd): 362 mm - 365 mm x 560 mm - 568 mm x 300 mm
- "Please reference the built-in dimensions provided in the installation drawing"

**Series 6, Built-In Microwave,
Stainless steel
BFL524MS0**

Microwave,
corner installation

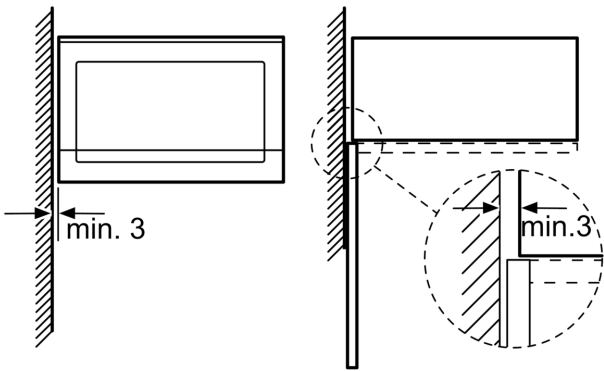

Measurements in mm

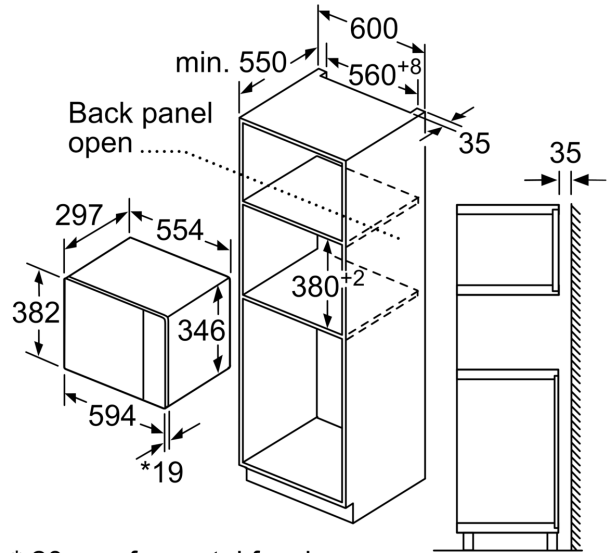

* 20 mm for metal fascia

measurements in mm

Measurements in mm

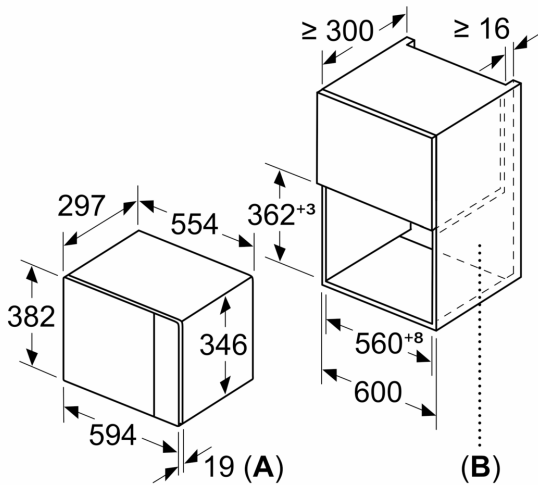

A: 20 mm for metal fascia
B: Back panel open

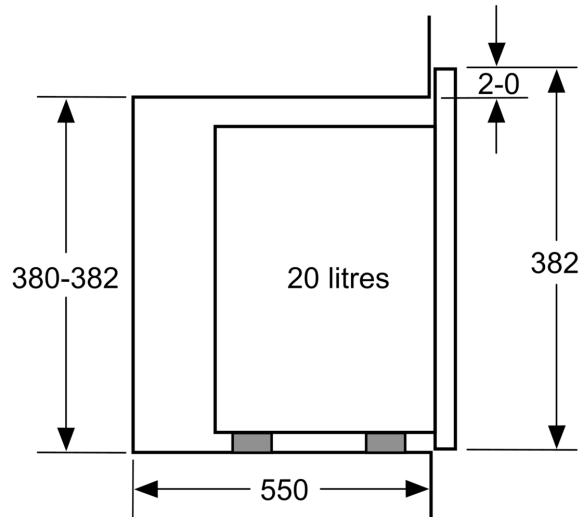

measurements in mm

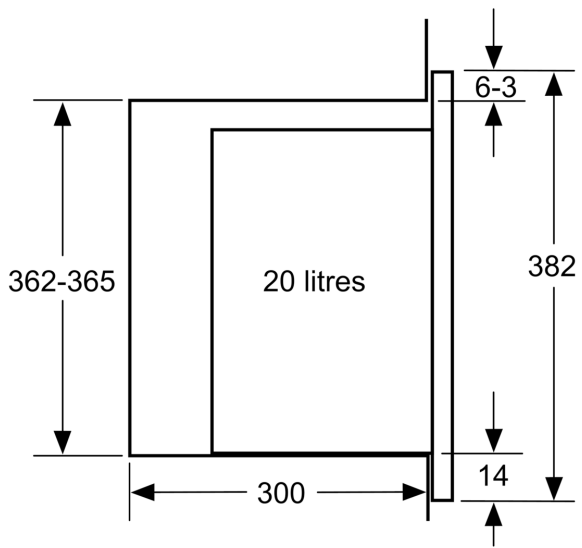

measurements in mm