

Series 8, Built-In Microwave, Black BER7321B1

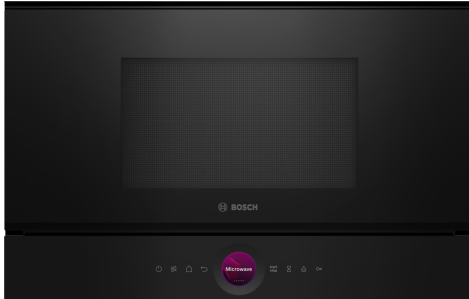

1 x grid, 1 x Glass tray

HEZ6TCC0 Cookbook
HEZG9AS00S Adapter

- **AutoPilot 10:** every dish is a perfect success thanks to 10 pre-set automatic programmes.
- **Stainless steel interior:** easy to clean interior thanks to smooth surfaces and no sharp edges.
- **Electronical door opening:** comfortable door opening just with a fingertip on the sensor button.
- **Convection Cooking Delivers Oven-Like Results**
- **Low Profile Design With Touch "Open" and "Close"**

Additional function:Grill function
 Type of control:Electronic
 Dimensions: 382 x 594 x 318 mm
 Cavity dimensions: 230 x 350 x 270 mm
 Length electrical supply cord: 175.0 cm
 Net weight: 18.5 kg
 Gross weight: 20.4 kg
 Max. microwave power level: 900 W
 Number of Power Levels: 5
 Turntable: No
 Cavity material: Stainless steel
 Door opening: Button
 Clock: Yes
 Included accessories: 1 x grid, 1 x Glass tray
 Height of the appliance: 382 mm
 Width of the appliance: 594 mm
 Depth of the product: 318 mm
 Max. microwave power level: 900 W
 Connection rating: 1990 W
 Fuse protection: 10 A
 Voltage: 220-240 V
 Frequency: 50; 60 Hz
 Plug type: Gardy plug w/ earthing
 Required cutout/niche size for installation (in):x
 Dimensions of the packed product: 18.50 x 18.11 x 26.37
 Net weight: 41.000 lbs
 Gross weight: 45.000 lbs



4 242005 319565

Series 8, Built-In Microwave, Black
BER7321B1

Measurements in mm

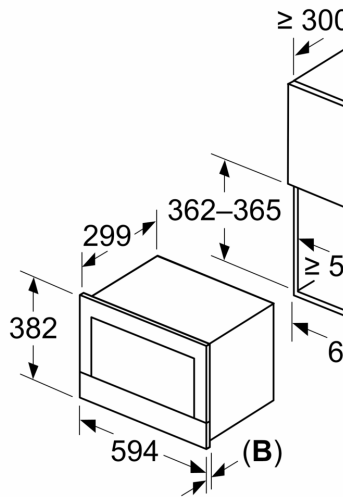

A: Back wall open
B: 19.5 mm

Measurements in mm

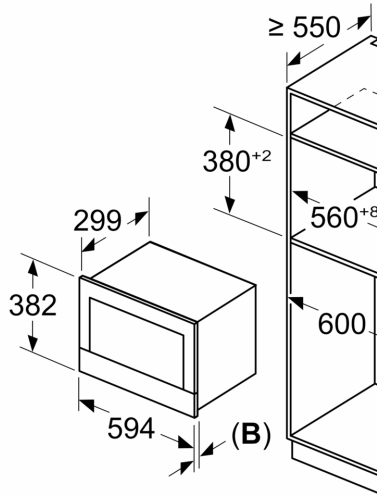

A: Back wall open
B: 19.5 mm

