

**iQ300, vented tumble dryer, 7 kg
WT34A202IN**



iSensoric vented dryer with large, easy-to-read display, and even faster drying cycles in all programmes.

- ✓ Duotronic moisture sensor: sensor-controlled technology prevents laundry from shrinking when being dried
- ✓ Sensitive Drying system combines warm air currents and a gentle drum structure for dry clothes
- ✓ softDry drum system: Soft and gentle drying
- ✓ Super40: Fast and careful drying of small loads
- ✓ autoDry - Achieves excellent drying results via sensor technology

Built-in / Free-standing: Freestanding
 Removable top: No
 Door hinge: Right
 Color / Material body: White
 Length electrical supply cord: 145.0 cm
 Dimensions: 842x598x601 mm
 Net weight: 33.8 kg
 Drum volume: 112 l
 Connection Rating: 2000 W
 Fuse protection: 10 A
 Voltage: 220-240 V
 Frequency: 50 Hz
 Drying process: automatic
 Capacity: 7.0 kg



WZ20180 Exhaust air hose
 WZ20311 Stacking kit

iQ300, vented tumble dryer, 7 kg WT34A202IN

Design

- Capacity: 7 kg
- Dryer type: Vented Dryer
- AutoDry saves time and energy by automatically stopping the drying process once it's complete
- Energy consumption 213.0 kWh per year, based on 160 drying cycles of the standard cotton programme at full and partial load, and the consumption of the low-power modes. Actual energy consumption per cycle will depend on how the appliance is used
- Energy consumption of the standard cotton programme at full load 1.71 kWh and energy consumption of the standard cotton programme at half load 1 kWh
- Energy consumption of 9kg cotton cupboard dry: 2.13 kWh
- Duration of left-on mode: 30 min
- The programme Cotton cupboard dry used at full and partial load is the standard drying programme to which the information in the label and the fiche relates, this programme is suitable for drying normal wet cotton laundry and is the most efficient programme in terms of energy consumption for cotton
- Noise level: 63 dB

Programmes

- Special programmes: Shirts (Business), Duvet, Pillow (Down), Outdoor, Towels, Hygiene, Super 40', Mixed Fabric, Woolen (Finish), Lingerie

Performance

- Anti crease cycle 120 minutes at the end of the programme
- touchControl buttons: start/pause, Gentle, Less Ironing, programme length, Fine-tuning of drying aim, 24 h Ready in

Key features

- Duo-Tronic Senors monitors moisture levels and temperature to reach desired levels of dryness and to prevent overheating
- Fully electronic control dial for sensor drying, including timed and special programmes
- LED Display for remaining time and 24 hours time delay, programme status indication, special functions
- softDrum system: Galvanised drum with textile care structure, soft design paddles
- Anti-Vibration Design: More stability and quietness
- Flexible exhaust-air duct
- Child-proof lock
- Buzzer at the end of the wash programme
- Reload Function
- Door hinge: right-hand

Technical Information

- Dimensions (H X W X D): 84.2 x 59.8 x 60.1 cm
- Noise level washing: 54 dB; Noise level spinning: 74 dB

iQ300, vented tumble dryer, 7 kg
WT34A202IN

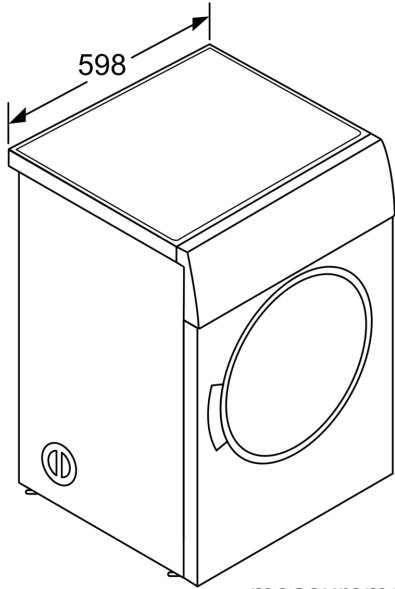

measurements in mm

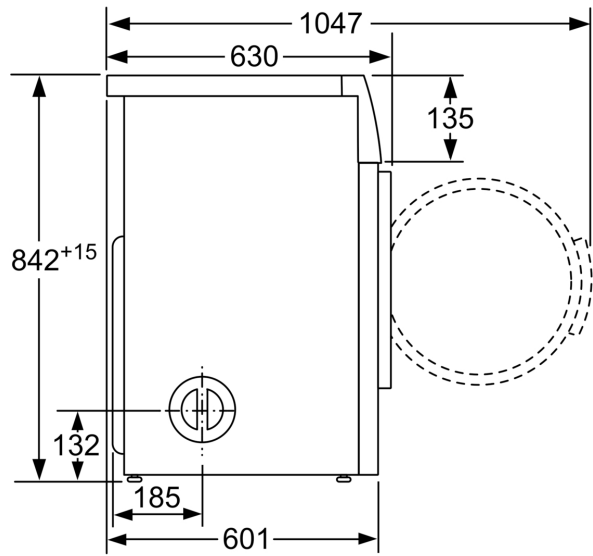

measurements in mm

Measurements in mm

