

iQ300, washing machine, front loader, 7 kg, 1200 rpm WM12J16WIN



WX975600 Floor securing component
WZ10130 Extension for cold water inlet /Aquastop

iSensonic Washing Machine with iQDrive for highly effective and efficient laundry care.

- ✓ Intelligent, durable and quiet iQdrive motor for highly effective and efficient laundry care
- ✓ Get perfectly clean laundry in up to 65% less time with varioSpeed
- ✓ waveDrum - Highly effective and extremely gentle laundry care
- ✓ Anti-Vibration Side Panels reduce vibrations and ensure greater stability during the washing and spinning process.

Built-in / Free-standing: Freestanding
 Door hinge: left
 Color / Material body: White
 Length electrical supply cord: 160.0 cm
 Height of the appliance: 848 mm
 Dimensions of the product: 848 x 598 x 590 mm
 Wheels: No
 Net weight: 72.1 kg
 Drum volume: 58 l
 Door Frame: White-black grey
 Noise level washing: 53 dB(A) re 1 pW
 Connection Rating: 2300 W
 Fuse protection: 10 A
 Voltage: 220-240 V
 Frequency: 50 Hz
 Energy Star Qualified: No
 Cord Included: Yes
 Plug type: India plug (16 Ampere)
 Length of supply hose (in): 59.05 "
 Dimensions of the packed product: 34.44 x 25.78 x 27.95
 Net weight: 159.000 lbs
 Gross weight: 169.000 lbs
 Length of drain hose: 150.00 cm
 Length of supply hose: 150.00 cm
 Dimensions of the packed product (HxWxD): ... 875 x 655 x 710 mm
 Gross weight: 76.5 kg
 Connection Rating: 2300 W
 Fuse protection: 10 A
 Voltage: 220-240 V
 Frequency: 50 Hz
 Water protection system: Multiple water protection
 Max. spin speed: 1200 rpm
 Spin speed options: Variable
 Digital countdown indicator: Yes
 Drying progress indicator: LED-display, LED
 Maximum capacity in kg (EU 2017/1369): 7.0 kg



iQ300, washing machine, front loader, 7 kg, 1200 rpm WM12J16WIN

Technical Information

- Capacity: 7kg
- Maximum spin speed: 1200 rpm
- Dimensions (H x W x D): 84.8 cm x 59.8 cm x 59.0 cm (61.8cm with door frame)
- 32 cm porthole, 165° swing door

Programmes

- Cottons, Cottons 60° Label, Synthetics, Mix, Delicates/Silk, Wool, Drum Descale, Rinse, Spin/Drain, Sportswear, Jeans/Dark wash, Hygiene, Kidswear, Freshen-Up, Super 15/30min

Features

- Intelligent, durable and quiet iQdrive motor for highly effective and efficient laundry care
- Speed up the washing process by up to 65% with the varioSpeed option.
- WaterPerfect™ Plus: Pressure and water sensor that measures the washing load and adjusts water intake to 256 precise levels for more cost and water savings
- WaveDrum's breakthrough wave-droplet design provides a thorough yet gentle clean for fine textiles
- Anti-Vibration Side Panels reduce vibrations and ensure greater stability during the washing and spinning process.
- Reload function to pause machine operation for adding in last minute laundry items
- Time delay to select end time of your wash (1 - 24 hours) and time remaining indicator
- Foam detection system to remove excessive foam

Safety

- Voltmonitor - monitors, regulates and feedback voltage fluctuations to manage unstable electrical supply to protect the washing machine and ensure a smooth wash cycle
- Multiple water protection with magnetic valve to minimise risk of leakage

Display Screen & Alerts

- Large LED display screen to indicate: Programme status, Temperature and Spin Speed Selection, Remaining Time and 24 Hour End Time Delay
- TouchControl buttons: Start/Reload, Temperature, SpeedPerfect, Rinse Plus, Spin Speed Reduction
- Buzzer at the end of the wash programme

iQ300, washing machine, front loader, 7 kg, 1200 rpm
WM12J16WIN

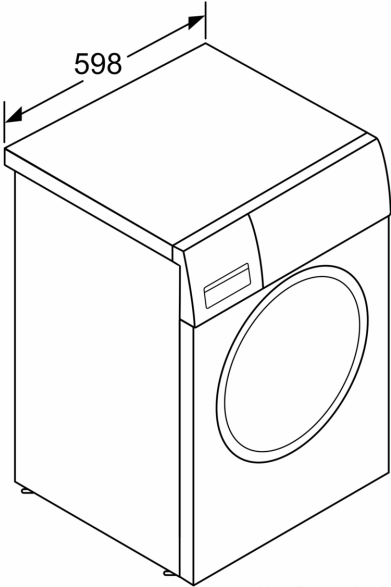

measurements in mm

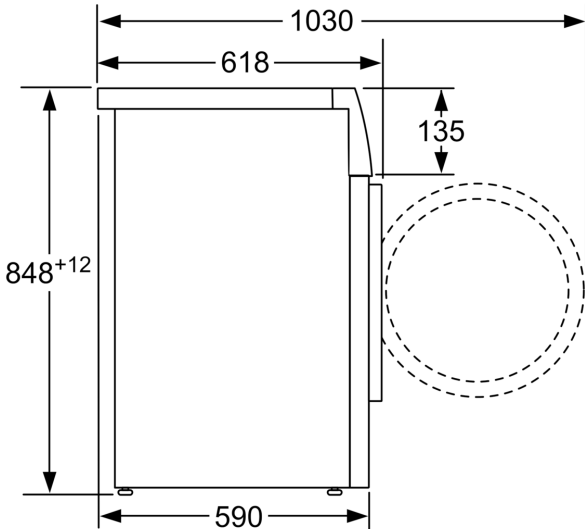

measurements in mm