

**iQ700, washing machine, front loader, 9 kg, 1400 rpm  
WG44A2A0IN**



- ✓ i-DOS automatic dosing system dispenses the precise amount of liquid detergent for perfect cleaning
- ✓ Speed up your programs or wash in just 15 min - speedPack L for washing machines
- ✓ Large LED-display - The numerous options and functions always in view. Thanks to touch buttons it is easy to use.
- ✓ Efficient, durable and quiet - iQdrive.
- ✓ waterPerfect Plus: for efficient use of water even with small loads thanks to intelligent sensor technology.

Built-in / Free-standing: ..... Freestanding  
 Door hinge: ..... left  
 Color / Material body: ..... White  
 Length electrical supply cord: ..... 160.0 cm  
 Height of the appliance: ..... 848 mm  
 Dimensions of the product: ..... 848 x 598 x 588 mm  
 Wheels: ..... No  
 Net weight: ..... 74.7 kg  
 Drum volume: ..... 65 l  
 Door Frame: ..... Black  
 Noise level washing: ..... 54 dB(A) re 1 pW  
 Connection Rating: ..... 2300 W  
 Fuse protection: ..... 10 A  
 Voltage: ..... 220 V  
 Frequency: ..... 50 Hz  
 Energy Star Qualified: ..... Yes  
 Cord Included: ..... Yes  
 Plug type: ..... India plug (10 Ampere)  
 Length of supply hose (in): ..... 59.05 "  
 Dimensions of the packed product: ..... 34.44 x 25.07 x 27.36  
 Net weight: ..... 165.000 lbs  
 Gross weight: ..... 166.000 lbs  
 Length of drain hose: ..... 150.00 cm  
 Length of supply hose: ..... 150.00 cm  
 Dimensions of the packed product (HxWxD): ... 875 x 637 x 695 mm  
 Gross weight: ..... 75.5 kg  
 Connection Rating: ..... 2300 W  
 Fuse protection: ..... 10 A  
 Voltage: ..... 220 V  
 Frequency: ..... 50 Hz  
 Water protection system: ..... Multiple water protection  
 Max. spin speed: ..... 1400 rpm  
 Spin speed options: ..... Variable  
 Digital countdown indicator: ..... Yes  
 Drying progress indicator: ..... LED-display, LED  
 Maximum capacity in kg (EU 2017/1369): ..... 9.0 kg



WX975600 Floor securing component  
 WZ10131 Extension for cold water inlet /Aquastop

iQ700, washing machine, front loader, 9 kg, 1400 rpm  
WG44A2A0IN

Measurements in mm

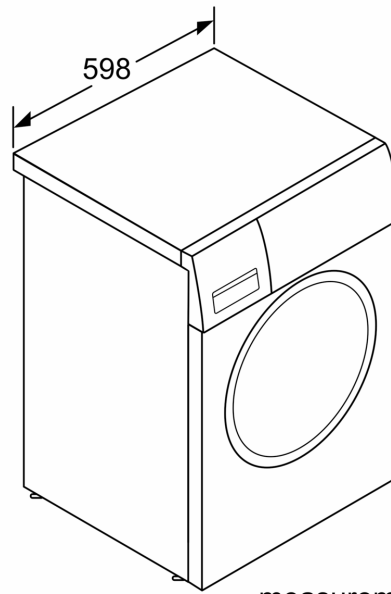
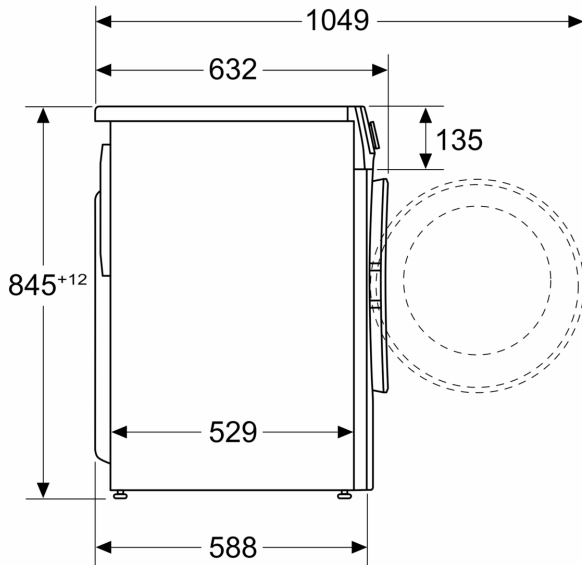

measurements in mm